

WATTROUTER ECO - USER MANUAL

FOR MODELS:
WATTROUTER ECO (WRE 01/06/14 AND WT 02/10)

HOW TO FIT AND SETUP THE DEVICE

Document version: 1.0

Last revision: 22. 12. 2014

Company: SOLAR controls s.r.o.

TABLE OF CONTENTS

General information.....	4
Description of basic function	5
Packaging contents	6
Safety warning	7
Fitting the device.....	8
Device configuration	17
USB driver installation.....	17
WATTconfig ECO control software installation	19
Basic regulator Setting	19
Setting up CombiWATT mode	22
Setting up time schedules	24
FB input configuration.....	24
Wireless communication settings	24
Finishing the configuration	25
Description of WATTconfig ECO items	26
Main window	26
Measured parameters and statuses	27
Input settings tab	29
Output settings tab	30
Time schedules tab	34
Other settings tab	35
Statistics tab	37
Log tab.....	39
Options and buttons	39
Serial port driver configuration window	40
Buy additional features window	41
SC-Gateway module status	42
LED statuses	43
Configuration examples	44
Example No. 1 – one load only.....	44
Example No. 2 – all 6 loads, control mode - sum of all phases	46
Example No. 3 – all 6 loads, control mode - each phase independently	48
Example No. 4 – 5 loads, control mode - each phase independently	50

Troubleshooting	52
Maintenance and repairs	56
Technical specifications.....	57
Recycling	58
Declaration of conformity	59

GENERAL INFORMATION

WATTrouter ECO is a programmable controller to optimize self-consumption of energy produced by photovoltaic or wind power plant (hereinafter referred to as PV-plant). It is a smart home energy management system. After correct installation and configuration, the regulator perfectly optimizes self-consumption of energy produced by your PV-plant. WATTrouter ECO consists of a current sensing module and the regulator itself.

WATTrouter ECO offers the following functionalities:

- Three-phase indirect current measurement.
- One phase detection of voltage necessary to determine the power direction on L1 and SW detection to determine the current direction on L2 and L3.
- Evaluation of active power outputs in individual phases, necessary to determine the surplus of produced electric power.
- Regulation based on the sum of power outputs (summary surplus) from all three phases or based on surplus in each phase.
- Switching up to 6 outputs (2 relays and 4 external solid state relays SSR) based on configured priorities.
- Switching up to 6 wireless outputs based on configured priorities (only with SC-Gateway module).
- Optimal use of surplus energy produced by PV-plant on SSR outputs through the application of proportional synchronous regulation of resistive loads, compliant to European standards EN 61000-3-2 and EN 61000-3-3. This regulation modulates connected load's power exactly according to the available surplus energy.
- Very short average dynamic response of the regulator (up to 10 s)
- Optional CombiWATT program used for switching loads under a combined mode where energy is taken both from PV-plant and public grid (especially suitable for water heating and also for swimming pool filtering system).
- Input for low tariff signal (night/low tariff) for CombiWATT. This is for households where double tariff rates will apply.
- 1 input for connection of impulse output of external energy meter, which may measure any power output. Measured value is displayed in WATTconfig ECO application.
- Separated current sensing module and regulator for easy installation into existing household wiring.
- WATTconfig ECO software designed for MS Windows XP and higher, provides comfortable regulator configuration and monitoring via USB interface.
- Real-time module backed up with a lithium battery for advanced management of outputs and CombiWATT function.
- Time schedules for outputs.
- Day, week, month and year statistics (only with activated SW feature).
- PWM mode for outputs allowing for proportional control of suitable heat pumps, air conditioners or battery chargers (only with activated SW feature).
- Firmware updates.

DESCRIPTION OF BASIC FUNCTION

The current sensing module measures electric current in real time and on all phases. The regulator evaluates the measured electric currents and if it determines the available surplus energy produced by the PV-plant, it will switch on connected loads according to adjustable priorities, while constantly trying to maintain zero energy flow through the current sensing module, the so called "virtual zero" (the sum of active power outputs on all three phases = 0) or optionally, on each phase separately, so called "phase zero".

Switching according to priorities is done in the following way:

By default (during night), all loads are turned off. If surplus energy generated by PV-plant is determined in the morning, the output with the first (highest) priority is switched on.

The switching moment is different for SSR outputs and relay outputs.

- SSR outputs are switched on almost immediately after surplus energy is detected and the regulator is gradually (synchronous control) maintaining "virtual zero" or "phase zero", according to the control settings.
- Relay outputs are switched on only if the surplus energy exceeds the preset load's nominal power. Alternatively, relay outputs may be operated in "prepend" mode if there is sufficient power at any proportional output with nearest higher priority. This allows for maximum utilization of the produced surplus power even for relay outputs - refer to the "Prepend SSR" function.

When load with 1st priority is fully switched on (for SSR output it means switching on the maximum power), the system waits until the power output of PV-plant increases again (beginning of dawn). If electric production is determined even when this load is switched on, load with second priority in the same mode is switched on as well.

If the power output of PV-plant is still increasing, additional connected loads are switched on in the same mode.

If the power output of the PV-plant decreases, or if another load - not connected to the WATTrouter device is switched on, the switched (active) outputs are disconnected - again according to preset priorities but in reverse order (the load with lower priority is disconnected first).

For relay outputs there may be set a minimum switch on time. If, simultaneously with a relay output the SSR output with higher priority is switched on, and the available surplus energy is reduced, the SSR output will try to reduce the power output of the load (even down to zero) in order to maintain virtual zero or phase zero on the current sensing module.

Except for the situation specified in the paragraph above, the regulator never violates the established priorities.

The above specified principle applies only to standard connection of the current sensing module, connected right behind the facility's main energy meter, so the WATTrouter device uses only the actual PV-plant surpluses (recommended settings). However, WATTrouter controller is versatile device and can be connected according to your needs. For example you can place the current sensing module just next to the PV inverter and then you can maintain the virtual or phase zero on that line.

The above specified basic control mode may be combined with another mode of output switching, provided that low tariff signal (double tariff rate) is available (CombiWATT mode), or with switching based on preset time conditions (time schedules).



This device is not designed for precise active power measurement (it is not a replacement for a wattmeter). Active power is measured with sufficient precision in order to maintain all control functions.

PACKAGING CONTENTS

Contents of packaging:

1 WATTrouter ECO regulator

1 WATTrouter ECO current sensing module

1 USB cable

1 short manual with links to this manual, software and firmware updates

SAFETY WARNING



When you receive your package, inspect the packaging unit for damages. After opening your package, inspect the regulator and the current sensing module for damages. Do not fit the regulator or the current sensing module if you see signs of mechanical damages!



Always have the regulator and the current sensing module fitted by a person with the necessary electrical certificate and qualifications. It is necessary that you read this manual thoroughly and observe all safety warnings and requirements specified herein.



The regulator and the current sensing module must be fitted in a dry room without excessive dust level. The room must be protected from direct sunlight and the ambient temperature must be maintained within the range mentioned in chapter Technical specifications below. Do not place the regulator or system electronic components near flammable objects!



Make sure that unauthorized persons, mainly children, cannot access the location where the regulator is fitted. There is a serious risk of electric shock!



Only connect outputs of the regulator to electrical loads which have been designed for this operation mode and for which the manufacturer does not explicitly prohibit connection via switching element!



The manufacturer is not liable for any damages occurred due to improper fitting or operation of the device! The owner is fully responsible for operation of the entire system.

FITTING THE DEVICE

WATTrouter ECO regulator may be fitted in a regular electrical distribution box onto a 35 mm DIN rail or attached to a wall using 2 screws with round or countersink head and with diameter up to 6 mm.

WATTrouter ECO current sensing module may be fitted in a regular electrical distribution box onto a 35 mm DIN rail.

Current sensing module supplied with the WATTrouter ECO regulator is fully compatible with current sensing module supplied with the older WATTrouter CWx, WATTrouter CWx SSR or WATTrouter M SSR regulator and vice versa. Current sensing module fitted together with the WATTrouter CWx (SSR) or WATTrouter M SSR regulator may therefore be used with WATTrouter ECO regulator (and vice versa).

Measuring inputs of the current sensing module may be connected as single, double, or triple-phase connections.

The recommended maximum distance of the current sensing module and the regulator is 2 meters. Bigger distance is acceptable, but it will slightly affect the measuring accuracy.

To interconnect the current sensing module and regulator use 4 wires with minimum cross-section of 0.2 mm². For example, if these wires are placed in a cable tray together with other power cables/wires, we recommend using a shielded cable and connect the shielding of the cable to a GND terminal.

To connect power supply to the regulator (L1 and N) use wires with a minimum cross-section of 0.5 mm², for example CY 1.5.

To connect SSR to SSR outputs, use wires with a minimum cross-section of 0.5 mm².

To connect loads to the outputs use wires with adequate cross-section corresponding with the power ratings of the connected loads.

To connect loads to SSR, use wires with adequate cross-section corresponding with the power ratings of the connected loads.

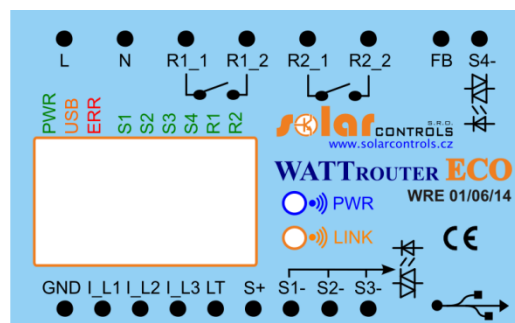

Figure 1: Connector and LED description (top view).

Regulator terminals - description:

- L – regulator power supply and voltage detection L1, 230VAC/50Hz (must always be connected)
- N – neutral wire (must always be connected)
- R1_1 – relay output 1 – terminal 1
- R1_2 – relay output 1 – terminal 2
- R2_1 – relay output 2 – terminal 1
- R2_2 – relay output 2 – terminal 2
- FB – input for connection of impulse output of external energy meter (0V or +5V)
- S4- – external output for SSR 4 – negative electrode (open collector)
- GND – common wire coming from the current sensing module (must always be connected)

- I_L1 – electric current measuring input L1 from the current sensing module (must always be connected)
- I_L2 – electric current measuring input L2 from the current sensing module
- I_L3 – electric current measuring input L3 from the current sensing module
- LT – low tariff signal detection (0V or +5V)
- S+ – external output for SSR – common positive electrode (+5V)
- S1- – external output for SSR 1 – negative electrode (open collector)
- S2- – external output for SSR 2 – negative electrode (open collector)
- S3- – external output for SSR 3 – negative electrode (open collector)
- USB – USB interface connector (USB B)

LED description:

- PWR – regulator power on light (green)
- COM – communication light - USB interface (yellow)
- ERR – error status light (red)
- S1 – external output for SSR 1 - activity indication light
- S2 – external output for SSR 2 - activity indication light
- S3 – external output for SSR 3 - activity indication light
- S4 – external output for SSR 4 - activity indication light
- R1 – relay output No. 1 - activity indication light
- R2 – relay output No. 2 - activity indication light
- Wireless PWR – LED indicator of SC-Gateway (optional accessories)
- Wireless LINK – LED indicator of SC-Gateway (optional accessories)

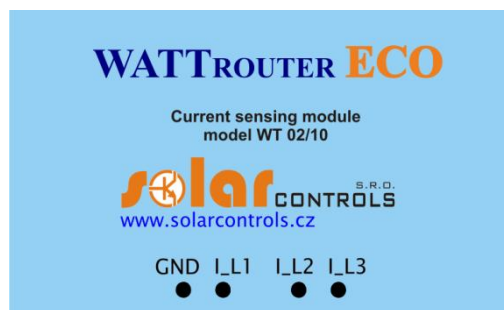

- **Figure 2: Terminals description of sensing module (top view).**

Current sensing module terminal description:

- I_L1 – current measuring output L1 (must be always connected)
- I_L2 – current measuring output L2
- I_L3 – current measuring output L3
- GND – common wire (must always be connected)



Regulator may be connected only to 230VAC, 50 Hz electric distribution grids. Regulator must be protected with a circuit breaker - recommended rating is B6A - and connected loads must also be adequately protected! Installation may only be done when the facility's main circuit breaker is turned off!



We strongly advise you to protect your loads connected to the SSR outputs with fuses suitable for protection of semiconductors, rather than regular circuit breakers. Please note that SSR outputs damaged by overcurrent or short-circuit cannot be claimed under warranty. Make sure that solid state relays are correctly connected, as required by the user manual.



For correct operation of the regulator it is absolutely necessary to ensure that the phase cable connected to terminal L1 corresponds with a cable passing through the measuring coil in the current sensing module, which belongs to the I_L1 input!

Current inputs I_L2 and I_L3 may be connected at random. Phase sequence can be set later in the control software.

Connect the regulator according to sample connection diagrams shown lower on figures. If you observe basic principles, connections may be combined in various ways. You may connect any number of loads to any outputs. In certain cases you may remove certain phase cable from the measuring, etc.

If CYKY or other thick and hard cables cannot pass through current transformers easily, use flexible cables to extend the existing connections. When fitting the current sensing module do not press hard on it. You may damage the module.

Tip: Individual phase wires may pass through the current sensing module from either direction. The direction of currents may be configured in the control software.

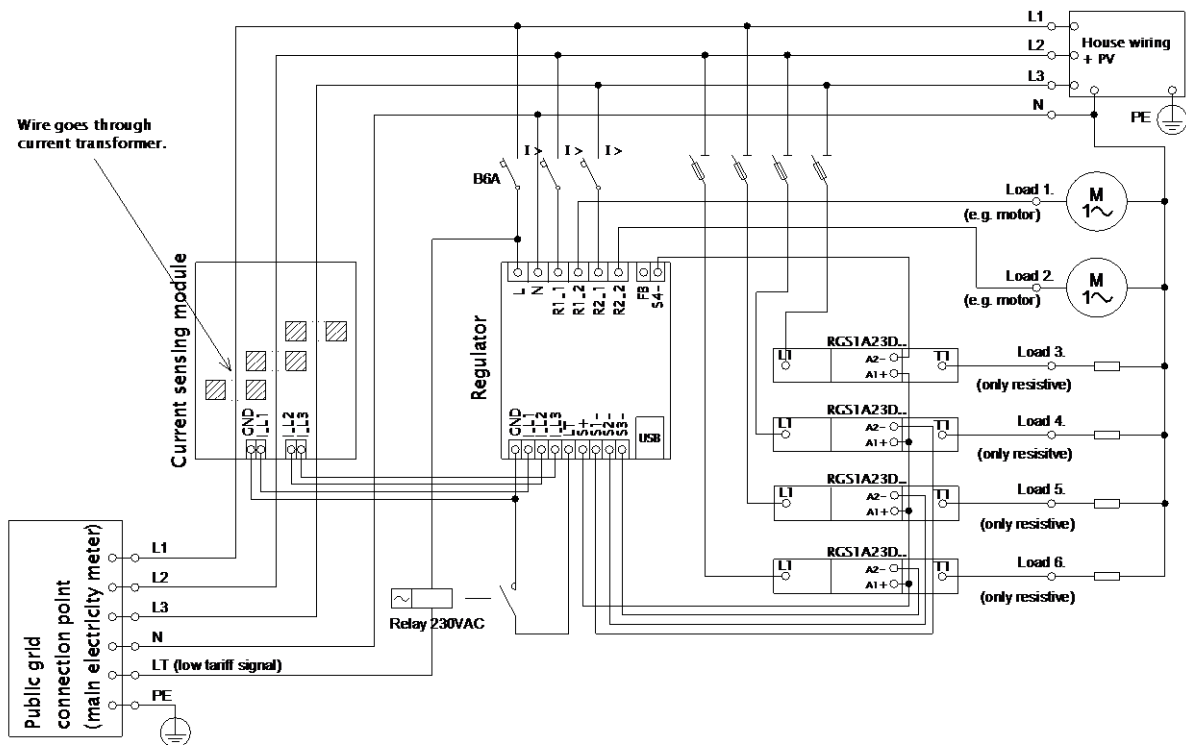

Figure 3: Three-phase connection with low tariff signal circuit for CombiWATT mode. Current sensing module is placed at the facility's supply cable coming from the distribution box where main energy meter is located. The connected loads use only real surpluses produced by PV-plant. All 6 loads are connected, 4 of them through the recommended SSRs RGC(S)1A manufactured by Carlo Gavazzi.

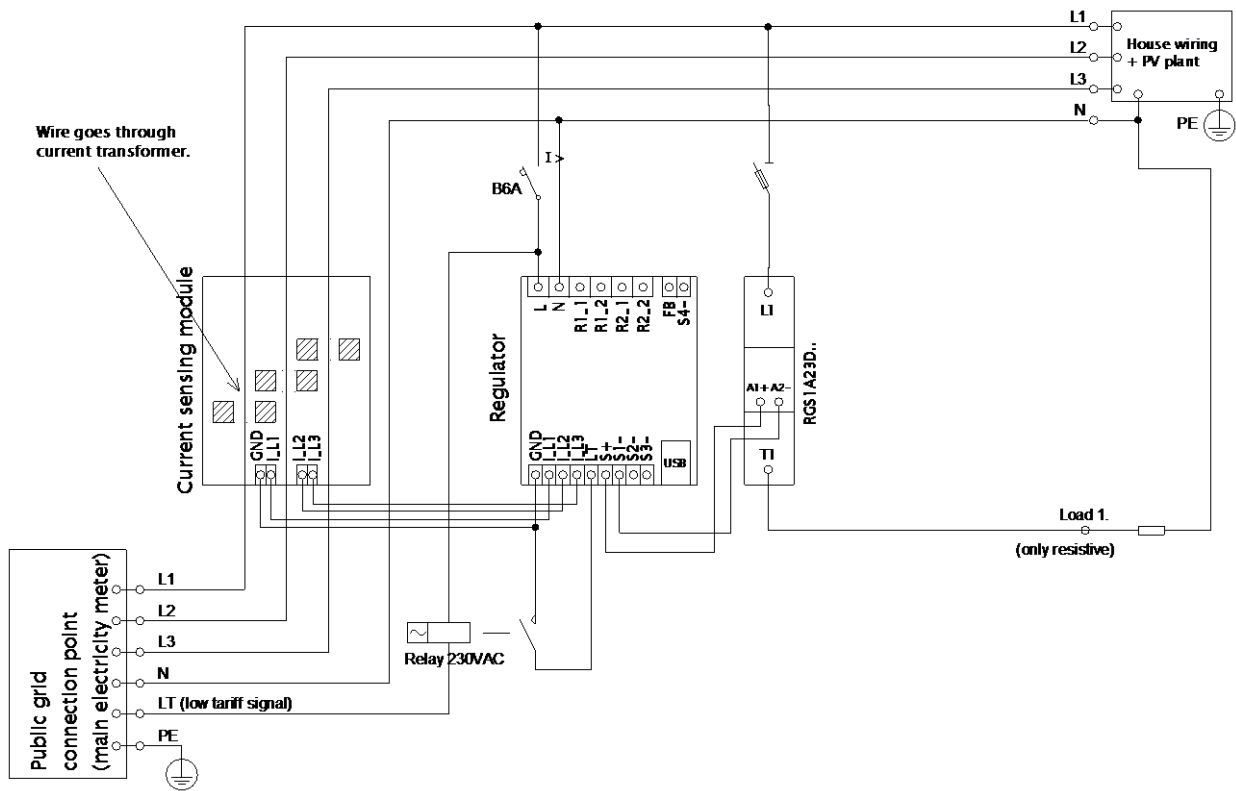

Figure 4: Three-phase connection with low tariff signal circuit for CombiWATT mode. Current sensing module is placed at the facility's supply cable coming from the distribution box where main energy meter is located. The connected loads use only real surpluses produced by PV-plant. This connection is one of the easiest – only one load (typically boiler or immersion heater) through the recommended SSR RGC(S)1A manufactured by Carlo Gavazzi.

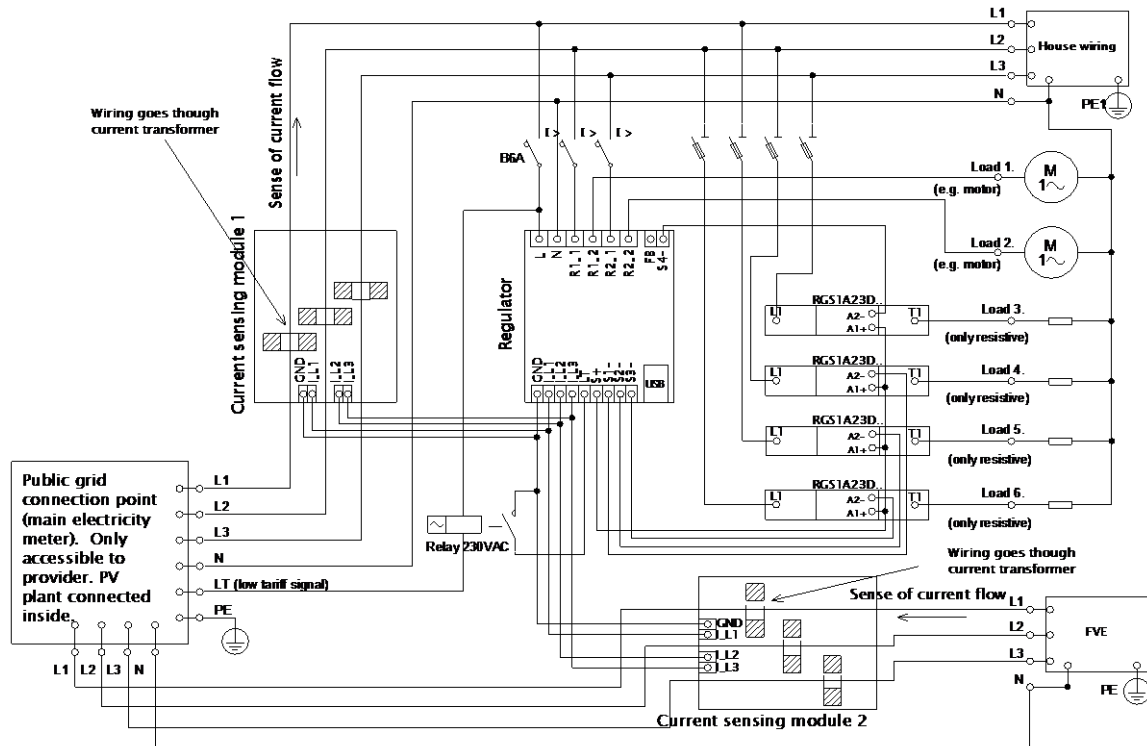

Figure 5: Three-phase connection with 2 current sensing modules and with low tariff signal circuit for CombiWATT mode. Here are connected all 6 loads, where 4 loads are over SSR through the recommended SSRs RGC(S)1A manufactured by Carlo Gavazzi. This connection is necessary if the PV-plant output is connected directly to a sealed distribution box, accessible only to the electricity provider. This may be the case for PV-plants made originally only for feed-in tariff, without self-consumption possibility. Current sensing module 1 is connected to the household wiring branch; current sensing module 2 is connected to PV-plant branch. The accuracy of measurement is reduced down to $\pm 10\%$ in this connection because of the finite impedance of current transformer secondary winding. **Caution: Current flow through current sensing modules must always be subtracted in this connection (marked with arrows on the picture). The same phase sequence must be observed in the regulator and in both current sensing modules!**

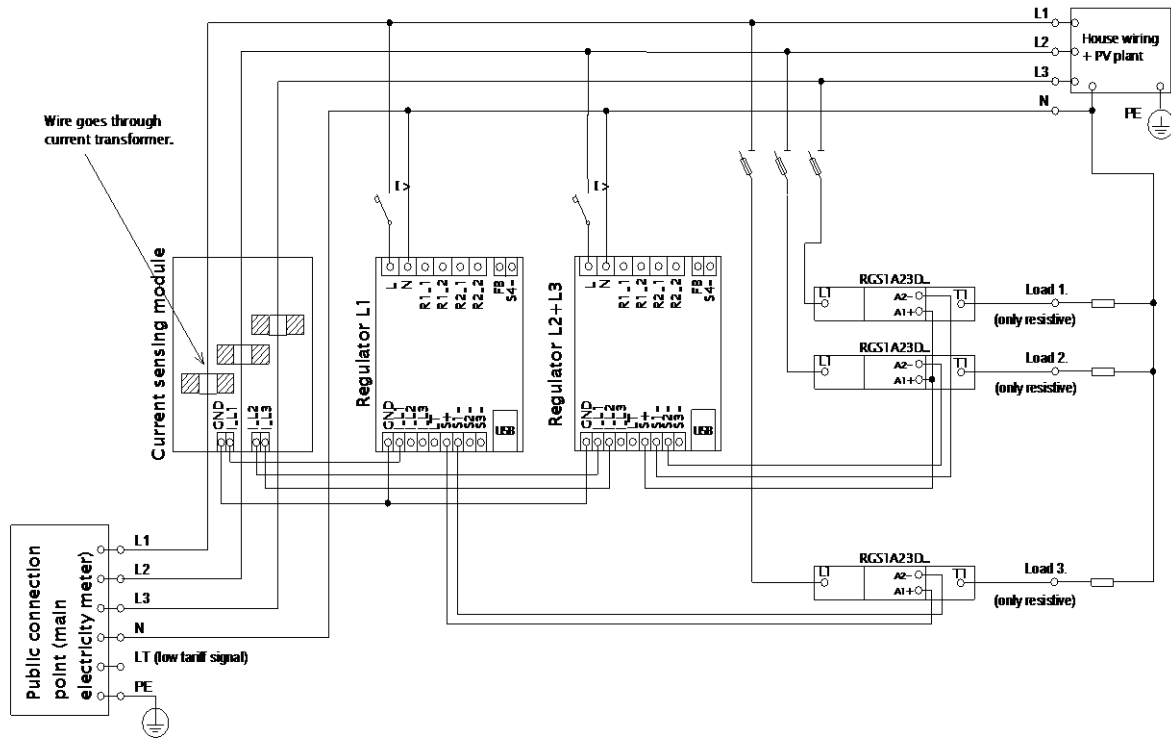

Figure 6: Three-phase connection of WATTrouter ECO with 2 regulators and without low tariff signal circuit (CombiWATT mode cannot be used). Using this connection you may extend the number of outputs up to 12. Current sensing module is placed at the facility's supply cable coming from the distribution box where main energy meter is located. Connected loads use only the actual surpluses produced by PV-plant. To make things simple, only 3 resistive (heating) loads are connected, but you may use all 12 outputs. Similarly, you may also connect 3 regulators to 1 current sensing module. In such scenario, each regulator works on one phase and you will get 18 outputs.

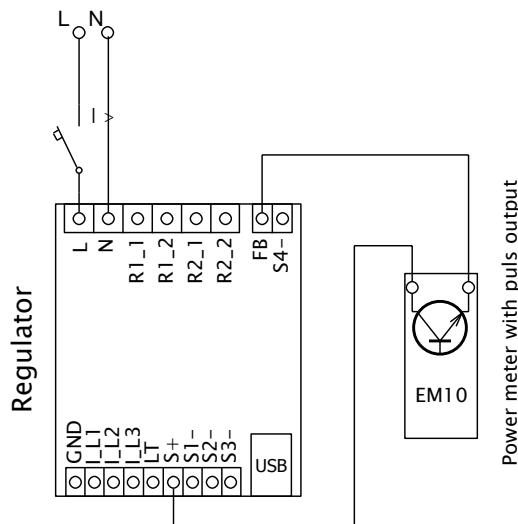

Figure 7: Connection of energy meter with pulse output S0 with input FB. On picture is type EM10 manufactured by Carlo Gavazzi.

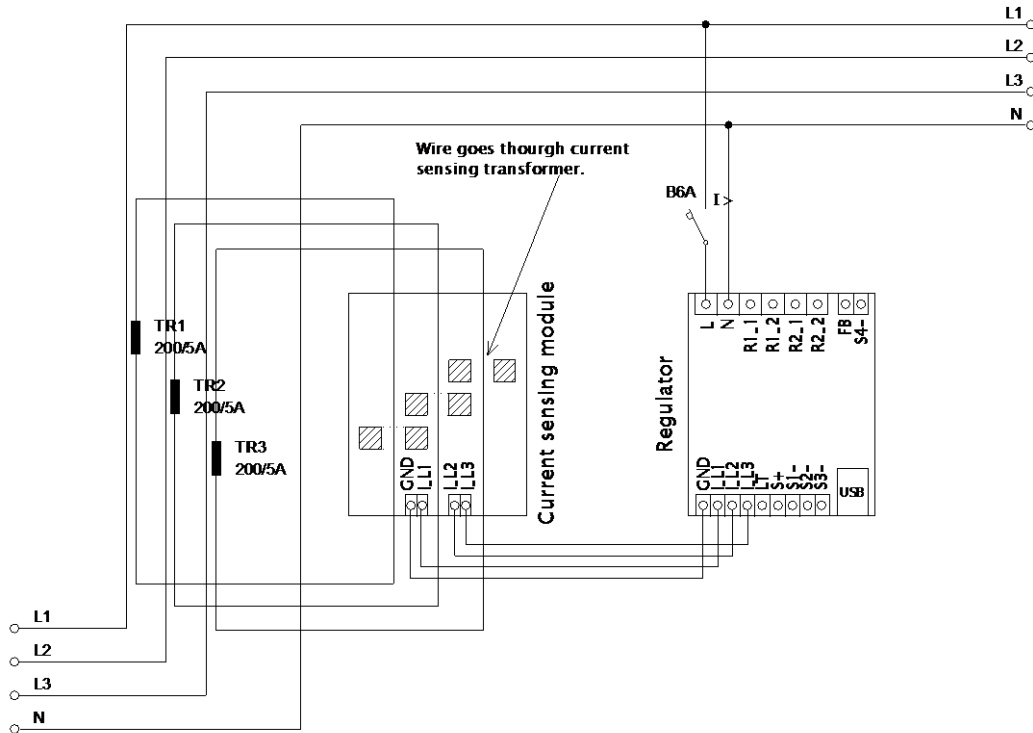

Figure 8: Increasing of current measurement range of the device for facilities where main circuit breaker is larger than 3x40A. Transformers 200/5A, or even 400/5A may be used, based on the main circuit breaker value. Secondary coil of current transformers is shorted through the current sensing module (the secondary circuit passes through measuring transformers in the current sensing module). Additional increase of current measurement range may be done if you take the secondary circuit of the current transformer and make several turns through the measuring transformer in the current sensing module (for transformers 200/5A, the best option is to make 4 turns in order to reach optimum transfer ratio 200/20A). For this purpose we recommend using lines, which are not overrated for the nominal secondary current, just to be able to make more turns through the hole of measuring transformer. When WATTrouter connected through external current transformers, the conversion ratio must be set correctly in the control software - see the item Conversion ratio of external CT's in the main window of the WATTconfig ECO software.

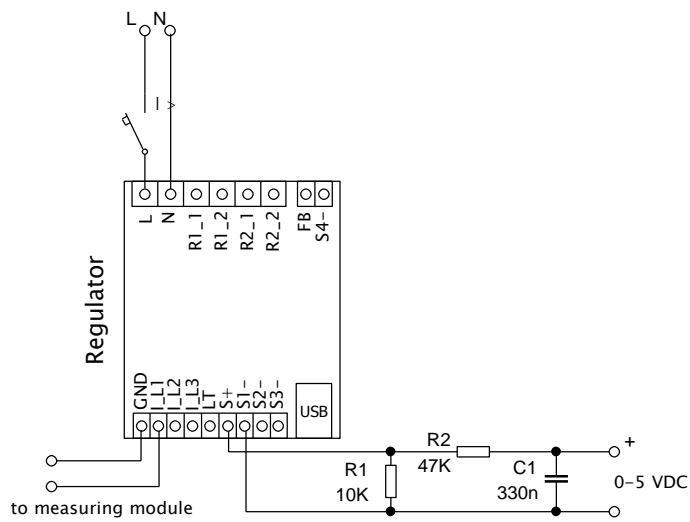

Figure 4: Connection of external devices controlled with a voltage of 0-5 VDC. The SSR output has to be operated in PWM mode. PWM signal is presented on terminal S1-(for output S2 on terminal S2- etc.). The filter element (R2 and C1) produces DC voltage with typical residual ripple about 300 mV. If you need inverted signal then connect the filter element between the S1- and GND terminals. The resistor R1 must always be connected between the S+ and Sx- terminals because the Sx- terminals have only open collector drive with a very weak internal pull-up resistor. The connected device must have a corresponding control input with sufficiently high input

impedance (which should not be below 200 k Ω), otherwise active filter could be necessary. Active filter must be always used, when the external device awaits another voltage (e.g. 0-10 VDC) or current loop (4-20 mA).

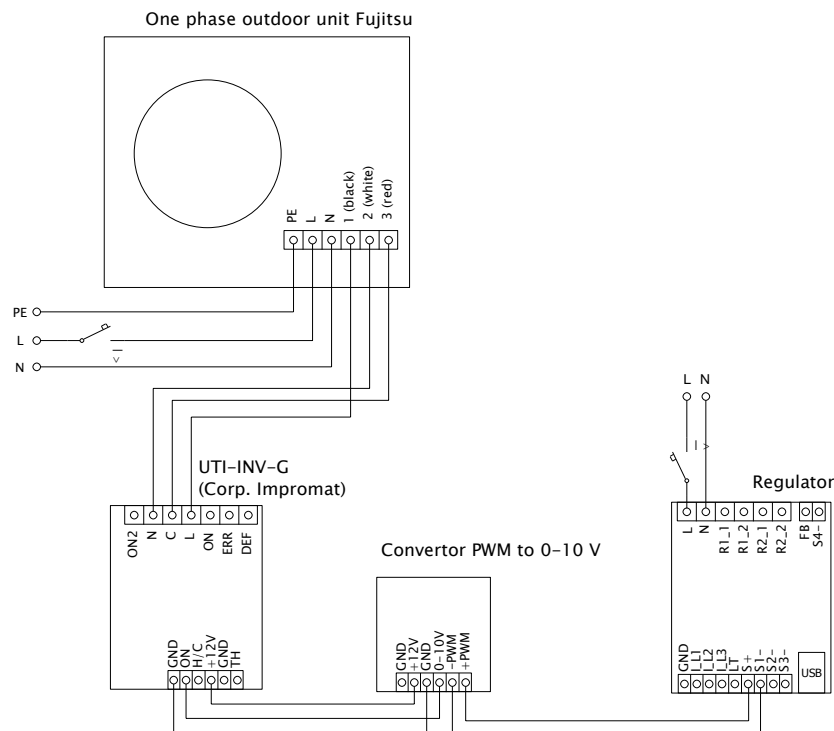

Figure 10: Connection of air conditioner or heat pump unit in mode of continuous regulation based on surplus energy. Here is listed example of outdoor unit Fujitsu controlled by module UTI-INV-G. Because this device is controlled by 0-10V, it is necessary to use a converter of PWM to 0-10V signal. For more about connection of heat pumps, see web pages of the manufacturer.



Upon completion of the installation process make sure to check thoroughly the connection of the regulator and the current sensing module. Also check connection of terminals GND, I_L1, I_L2, I_L3, LT, S+, S1-, S2-, S3-, that means all terminals located at the lower section of the regulator. **NO** power grid voltage or voltage outside of tolerances specified in the chapter Technical specifications may be connected to these terminals! Same has to be applied for terminals FB and S4- located in right top corner of controller. **NO** other than resistive (heating) loads may be connected to SSR outputs! Regular relays **CANNOT** be connected to SSR outputs! It is prohibited to connect loads with higher than the maximum allowed nominal power! If you fail to observe this rule it is almost guaranteed that you will damage the regulator and lose your warranty!



If your facility is located in an area with higher risk of overvoltage spikes due to atmospheric discharge (lightning), we strongly recommend fitting a suitable overvoltage/lightning protection between the distribution box with the main energy meter and the current sensing module!



If the regulator is constantly connected to PC via USB interface (mostly if long cable is used), we strongly recommend using an USB isolator!

It is allowed to connect only pure resistive loads to SSR outputs. These loads cannot be fitted with own electronic control system nor with built-in motors (e.g. fans - see the note below). These loads may only have regular mechanically controlled thermostats and indication LEDs or neon lamps. Almost any regularly produced boilers, immersion heaters, infrared radiators, heating floor pads, motor-free dryers (infra dryer), oil heaters, cartridge heaters in a solar tanks, etc. may be used.

Note: Heating loads connected via residual-current circuit breaker may be connected to SSR outputs.

Note: Heating loads with nominal power up to 2.3 kW may be connected to relay outputs directly, without using external contactor.

Pulse output from external energy meters may be connected to FB input. You may also use energy meters whose pulse outputs are fitted with optically isolated switch or an optocoupler with open collector. These energy meters may measure any power outputs. Measured values are displayed in the control software WATTconfig ECO. For example, these inputs may be used to connect energy meters which measure the actual net production of PV-plant. This net production cannot generally be determined by the current sensing module.

Carefully examine connection of the regulator and then turn off all circuit breakers and deactivate fuse switches for SSR outputs. Then turn on the main circuit breaker and the regulator circuit breaker (L1 power supply). The LED PWR lights up (power on indication). If the light is off, or if it does not shine permanently, or if the LED ERR starts to flash (error status), proceed according to instructions specified in the Troubleshooting chapter. In default status no output is active and therefore, no load will be turned on.

Now the regulator is fitted and ready for configuration.

DEVICE CONFIGURATION

You will need notebook or regular PC (placed closely enough to the regulator) with USB interface (hereinafter referred to as a computer only). The regulator is configured using the WATTconfig ECO control software. The installation package for this software is available on manufacturer's web pages. Before installing the WATTconfig ECO control software you need to install the driver for USB interface.



In order to connect to the USB interface, it is necessary - due to safety reasons - to turn off the entire distribution box before manipulation.

If you cannot continue with the settings (due to any reasons), proceed according to instructions specified in the Troubleshooting chapter.

USB DRIVER INSTALLATION

The installation procedure is described for Windows XP, English locale. The procedure is similar for newer systems, or it is much simpler (Windows 7 and later).

1. Insert the attached USB cable to the USB connector of the regulator and then to the computer.
2. Turn on the regulator. The green LED PWR must light up (power on indication). Also the yellow LED COM light will or should flash briefly (communication process indication) as the USB device will start to register in your computer.
3. After a moment, following window must appear confirming that a new device was found:

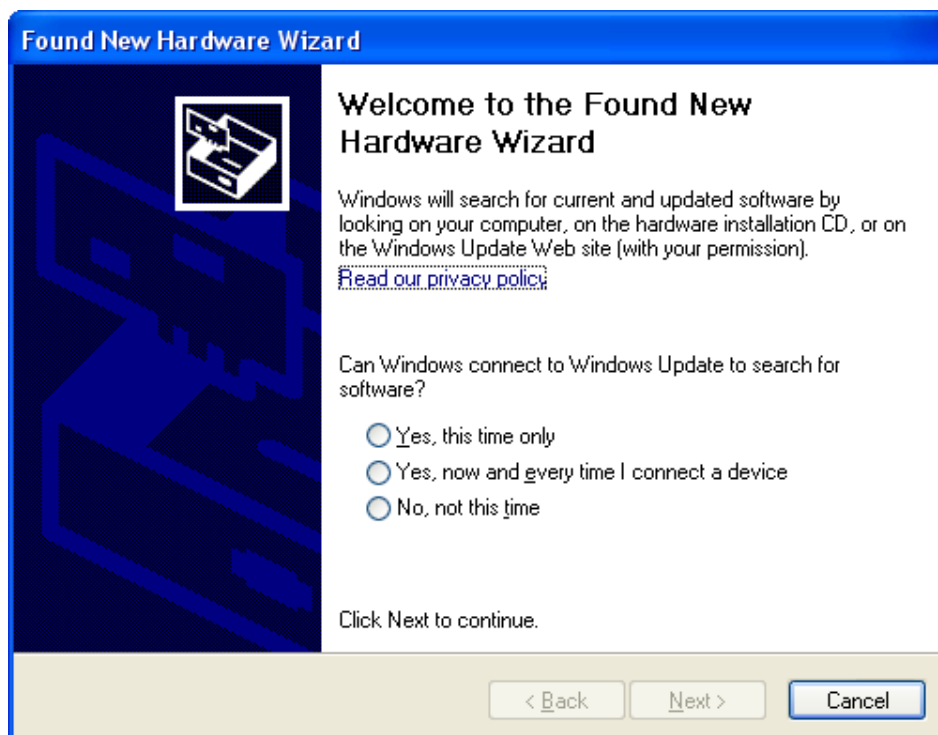

4. Select: No, not this time. In the following window select: Install from a list or specific location (Advanced).

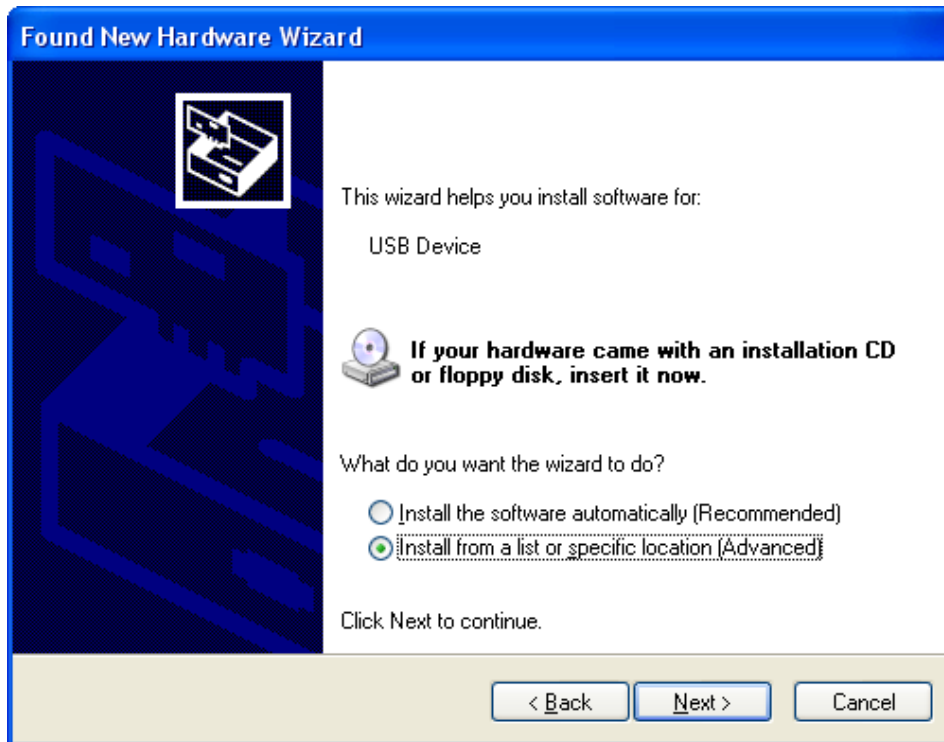

5. Select the path to the driver file:

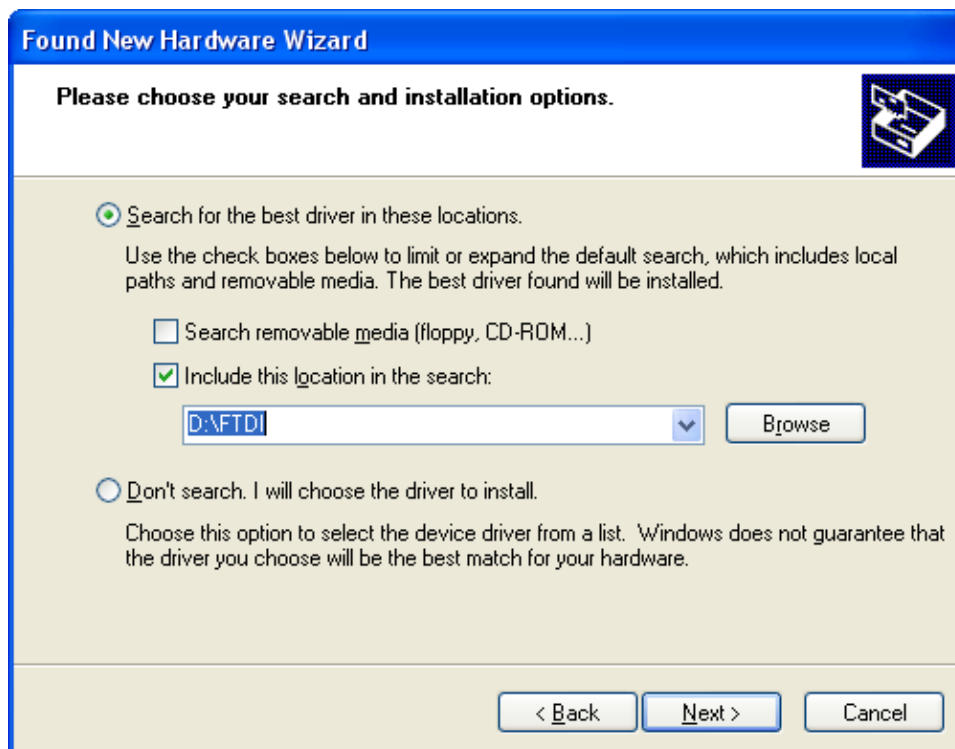

6. If the driver has been installed successfully, this window appears:

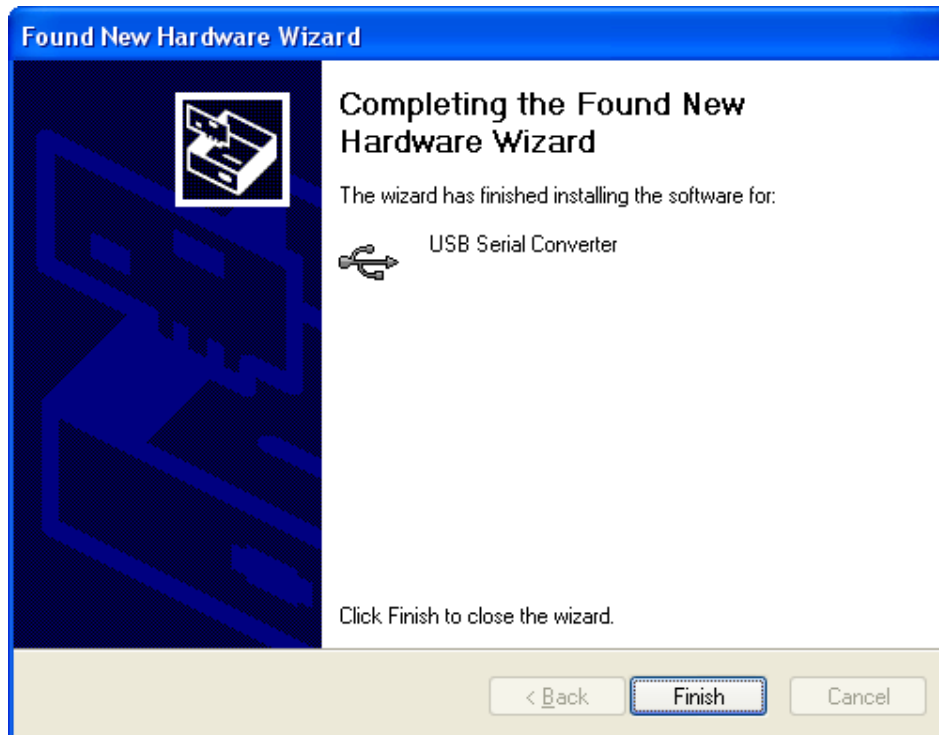

7. During the installation there might appear a warning about an invalid digital driver signature. Just ignore it. The device is registered in your system device manager as USB serial converter (menu Universal Serial Bus Controllers)
8. You must perform the same installation process for the second USB serial port device.

WATTCONFIG ECO CONTROL SOFTWARE INSTALLATION

1. Turn on the PC.
2. Run WATTconfig_ECO_Setup.exe which you may download from manufacturer's web pages.
3. Follow the on-screen instructions.

BASIC REGULATOR SETTING

1. Click on START button in your PC and run the WATTconfig ECO control software. The system will display the main software window.
2. Make sure that the regulator is turned on and connected to your computer. Make sure that USB interface driver is correctly installed.
3. Select correct port for connection. This can be done in the dropdown menu Port in Serial port driver configuration window, which will show up by clicking on button Configure connection.

Note: Unlike WATTrouter CWx or WATTrouter M devices the WATTrouter ECO uses a serial port connection (COMx). This port is always virtual port because the controller is connected via USB. Once more ports are displayed, it is necessary to check in Windows device manager, which port is assigned to USB Serial Port.

4. Click on the Connect button. The regulator should be connected now and the connection indicator (a stripe) should be displayed in green. If it is not, and the system displays an error message, wait until the USB driver is ready for use in your PC or inspect the settings in Serial port driver configuration window. This window will be displayed by pressing Configure connection button.

5. After establishing successful communication, you should be able to see the current measured values (power outputs on individual phases, regulator temperature, etc.). No outputs should be active ("unused" priority). Also no time schedules should be used.
6. Now you can configure measuring inputs. This can be done on the "Input settings" tab. First, you set the phase sequence and then the direction of current flows through the current sensing module.
 - a. **Setting up phase sequence:** Turn off the PV-plant and turn on a resistive load on each phase which will be involved in the measuring process. The system will display measured active power on each individual phase. For now, you may ignore the signs of the measured power values. Now, in the Phase order settings field you choose "L1, L2, L3" or "L1, L3, L2" and then press Write button. This setting will be saved in regulator. If the output values measured on individual phases differ too much from the reality, check whether the phase connected to input L1 corresponds with the measured input I_L1. If everything is ok, select a reverse phase sequence configuration (that is, if the sequence "L1, L2, L3" was previously set then select "L1, L3, L2" sequence and vice versa). Press the Write button. The configuration will be saved in the regulator.
 - b. **Setting up the direction of current flows through the current sensing module:** As specified in the previous steps, leave loads on measured phases switched on. When the PV-plant is turned off, **all measured power output values must be smaller than 0 or equal to 0**. If any of the measured power outputs is positive it means that the phase wire is passing through the current sensing module in a reverse direction. Use the Current orientation field for the relevant phase, select opposite and press the Write button. The configuration will be saved in the regulator. Now, all measured power outputs must be ≤ 0 . Turn the PV-plant on and turn off all loads. **Now, measured outputs must be positive (≥ 0)**. If they are not, or if the measured values do not correspond with nominal power ratings of the connected loads, or if they do not correspond with the power output of the PV-plant, you have either still connected another loads (which you don't know about, such as various loads in stand-by mode, etc.), or the phase sequence in voltage or in current inputs does not match, or you may have a defect in household wiring. **In any case, make sure to inspect the entire electric wiring.**
 - c. You can verify the correctness of measurement input configuration by using the chart "**Current wave oscilloscope**". This chart shows measured current waveforms in selected phase, values are given in units of the built-in A/D-converter (digits), these are not normalized to amps due to performance. This feature should only aid the fitter when configuring the measuring inputs. **Always verify with a resistive (heat) load only, so that the phase shift between voltage and current is zero ($\cos(\varphi) = 1$)! Moreover, in order to verify the measuring inputs the amplitude of current half-wave should always be greater than 1000 digits** (to be sure about the correctness of the settings).

***Note:** During normal operation there may be shown even "exotic" waveforms. Be sure this is the real current flowing through the phase wire, a superposition of currents flowing through the connected appliances which are not sinusoidal or their power factor varies from one.*

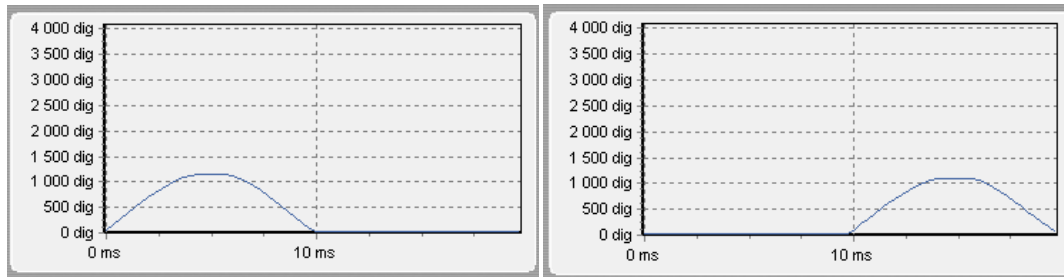

Figure 51: Input is fitted correctly - sine wave of the current flowing through a resistive (heat) load is in phase with the voltage. WATTrouter ECO shows negative values on selected phase (consumption). Left image appears when there is normal (default) current flow direction, right image appears for opposite direction. Note: The PV-inverter throughput appears exactly as the opposite, because the current is anti-phased with the voltage. If the inverter performs power factor compensation you can observe corresponding phase shifts.

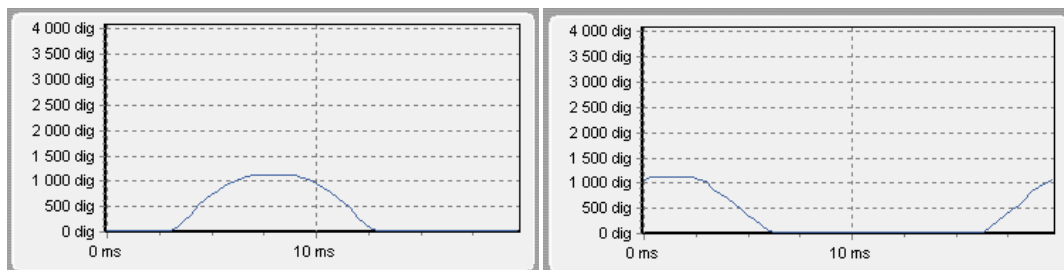

Figure 62: Input is fitted incorrectly - sine wave of the current flowing through a resistive (heat) load is not in phase with the voltage and either precedes (left image) or lags behind (right image) the voltage by 1/3 of mains half-wave. Measuring inputs are fitted incorrectly and you need to switch wires connected to I_Lx inputs of the regulator.

7. After a successful setup of measuring inputs you may begin to test outputs. This can be done on the "Output settings" tab. Each connected load must be tested separately. Turn on circuit breaker or activate fuse switch for the first output, and press the TEST button for the corresponding output. The load should switch on. Further, when the load is switched on, the active power drawn by connected load must be detected by the current sensing module on the relevant phase.
8. After you have successfully tested all outputs, you may begin to configure the control mode in the Control settings field. This can be done on the "Input settings" tab. Set this mode either to "sum of all phases" or to "each phase independently", based on the configuration of your 4-quadrant energy meter. If you are not sure how your energy meter is configured, please contact your electricity provider or use the "each phase independently"-mode, which works for any configuration of the energy meter.

In order to use the "each phase independently"-mode, it is necessary to select correct phase for each output, i.e. phase where the corresponding load is really connected. Regulator will then try to maintain zero energy flow in each phase ("faze zero"). You may check correct phase assignment again through the TEST button. Within a short time after pressing the button the active power drawn by connected load must be detected by the current sensing module on relevant phase.

As far as your energy meter is configured to evaluate sum of powers in all phases, you may use the mode "sum of all phases". Here the regulator will try to maintain virtual zero energy flow. This means that for output switching it takes the sum of measured powers from all 3 phases ("virtual zero"). Here you may try experimenting with both methods, but it is recommended to use "sum of all phases"-mode, because it is more effective for the user.

9. After a correct setup of the control mode, you may start to assign priorities and power ratings for individual outputs. This can be done on the "Output settings" tab. Select priorities of individual loads. The switching process based on priorities may be described as follows:

By default (during night), all loads are turned off. If PV-plant production (available surplus energy) is determined in the morning, the output with the first (highest) priority is switched on. The switching time is different for SSR and relay outputs. SSR outputs are switched on almost immediately (this is the proportional switching), but relay outputs are switched on only if the available surplus energy exceeds the value specified in the Connected power field (there is also a different solution available – see the "Prepend (SSR)" function). When the load is switched on (for SSR output it means switched to the value specified in the Maximum power field), the system waits until the power output of PV-plant increases again (sunrise). If additional available surplus energy is determined when the load with first priority is switched on, then load with second priority is switched on in the same mode. The same applies to all outputs. If the available surplus energy decreases, or if another load in the household is switched on, active outputs are disconnected according to preset priorities but in reverse order (first, the load with the lowest priority gets disconnected).

The value in the "Connected power" field should be equal to the power rating of the connected load. For relay output it must be higher or equal to the power rating of the load, otherwise the regulator will not operate correctly, and the load will be repeatedly turned on and off. For SSR this value only configures the regulation dynamics, but it should be also equal to the actual power rating of the load.

The fields On-delay time and Off-delay time for relay outputs specify the time delay to switch the relay on or off after a condition has been detected to do so. This feature is necessary for loads which cannot be switched on frequently.

Set outputs according to the connected loads and based on your priorities and then press the Write button. The configuration will be saved in the regulator. Now the main function of the regulator should be configured.

10. Test the main function of the regulator, or possibly, modify priorities for outputs and power settings of connected loads.

SETTING UP COMBIWATT MODE

After you have successfully tested the main function, you may start to configure CombiWATT mode, provided a low tariff signal is connected to the regulator (it may be used even if single tariff rate is present – see notes below). This can be done on the "Output settings" tab. CombiWATT mode provides constant daily energy supply to the connected loads. This mode is indispensable if you need to heat up water but also e. g. if you use a swimming pool filtering system during cloudy days or when your PV-plant is temporarily out of order. In CombiWATT mode, energy is taken both from PV-plant and from public grid.

Determine the optimal value of energy in kWh for the connected load (for example for a boiler or immersion heater), which you plan to supply the load with every day. For example, for a boiler it is suitable to determine the value of electric energy based on the average consumption of warm water. Usually, electric energy

$$E[kWh] = \frac{c_v * V[l] * \Delta T[K]}{3600000}$$

necessary to increase the temperature of water by 40°C equals to: . If you enter it into the formula you will get: $E[kWh] = 0.0464 * V[l]$. For a 180 liter boiler it will be 8.36 kWh. We recommend to increase this value by the daily heat loss of the boiler and also to modify (reduce) the value based on the actual average consumption of warm water.

Note: If you are heating water for example, the regulator does not "know" how hot the water in the boiler is and therefore, the assumed values of the supplied electric energy may be higher than the actual delivered energy (the boiler thermostat may shut it off at any time).

Mark the CombiWATT field for the relevant output (output must be activated, which means that the output must be assigned with the relevant priority), enter the established value of the daily electric energy in kWh and press the Write button. The configuration will be saved in the regulator.

The CombiWATT mode is activated only if ALL the following conditions are met:

- a. The output is activated (priority has been assigned to the output - that means the output is not in the "not used" status).
- b. PV-plant does not produce electric power (active powers at all measured phases are \leq (less than or equal to the) CombiWATT production limit field).
- c. During the day, PV-plant did not supply the load with the required amount of energy, that is, the field "Assumed supplied energy" is lower than the value specified in the "CombiWATT [kWh]" field for the relevant output.
- d. Low tariff signal has been detected (the information field "low tariff" is red). Energy from public grid is always consumed in CombiWATT only if low tariff is present. See note below to learn how to configure this mode if you don't have double tariff rate.
- e. The "Time to activate CombiWATT"-field shows zero.

The CombiWATT mode is deactivated if some of the following conditions will apply:

- a. The value in the field "Assumed supplied energy" reached the "CombiWATT [kWh]" value for the relevant output.
- b. Production has been detected at some of the measured phases (active power at some measured phase is $>$ (greater than the) CombiWATT production limit field).
- c. The low tariff signal is turned off.

Reset of energy counters (that is reset of values in the fields "Assumed supplied energy")

- a. At sunrise. Counters are reset to zero at sunrise time, which is automatically calculated by the regulator.
- b. At fixed time. Counters are reset to zero at a preset time.

More information about counter reset processing is available in the chapter WATTconfig ECO control software description.

Note: For boilers or any other warm water tanks the CombiWATT mode "does not care" during what time of the day the water is heated and used. The CombiWATT function only supplies the preset minimum daily power to the boiler and thus making sure that there is enough warm water when the recommended configuration is used. In cases when even under the recommended configuration warm water is not available in required amount, we recommend to gradually increase the daily energy limit ("CombiWATT [kWh]") for example, in 1 kWh steps, in order to make sure that warm water is available and at the same time that not too much energy is consumed from public grid. This is recommended mostly for households where consumption of warm water is high at the evening. Here it may come to the situation where water is sufficiently heated during the present day by the PV-plant, but the next day the plant is not capable of providing the necessary amount of energy (cloudy weather). The CombiWATT mode may also be aided by enforcing the relevant output with a time schedule. Based on user preferences, time schedules may even completely replace the CombiWATT mode. For more information see chapter "Setting up time schedules".

If you do not have low tariff signal available (either you don't have double tariff rate or the signal cannot be utilized) but you still want to use the CombiWATT mode, connect the GND terminal to the LT terminal. In such

scenario, the low tariff signal will be active at all times and the CombiWATT mode will be activated after production of PV-plant comes to an end (after sunset).

SETTING UP TIME SCHEDULES

For every output there may be set 2 independent time intervals. During these time intervals the relevant output may be forced to be switched on or the switching process may be prohibited (restricted). The enforcing/restricting process may be further conditioned with the presence of the low tariff signal and / or by the status of daily energy counters for the relevant output (field "Assumed supplied energy").

The actual configuration of time schedules is done on the "Time schedules" tab. For more setup information, see the chapter Description of WATTconfig ECO items, Time schedules tab.

FB INPUT CONFIGURATION

The regulator has 1 impulse input FB. It can be used to connect external energy meter or other device with impulse output which comply with FB input parameters listed in technical specification. The output signal of this device must always provide information about measured electric energy.

FB input is not required to be used and it plays an auxiliary role. FB input provides additional information to the regulator displaying in the WATTconfig ECO software.

Values obtained from FB inputs only provide information for the user and are not used to control WATTrouter device outputs.

Configuration of impulse inputs is done on the "Input settings" tab. For more information about the settings see the chapter Description of WATTconfig ECO items, Input settings tab.

WIRELESS COMMUNICATION SETTINGS

Note: This function is accessible, once SC-Gateway module is inserted.

WATTrouter ECO optionally integrates up to 6 wirelessly controlled devices which can be purchased as accessories. Wireless connection solution can be applied in buildings, where installation of wire connections between controller and devices would be too difficult.

Attention: Before ordering of this accessory function, assure that wireless devices will be accessible by the controller. The accessible distance is based on construction of the building and it is possible to extend this range by the repeaters. Further information can be obtained from technical support.

This function requires SC-Gateway module which needs to be inserted to regulator. To install this SC-Gateway module, refer to the SC-Gateway user manual. It is also necessary to buy at least one wireless peripheral (wireless socket or wireless module to be installed on the DIN rail).

How to activate wireless peripherals:

1. Connect wireless peripheral to electrical network and wait till the device gets registered in wireless network. SC-Gateway module acts as a coordinator of this wireless network and regulator is being informed once new device is detected. In such case, WATTconfig ECO software will show the Add wireless station window. If this dialog does not appear even after longer period (1 minute or longer), the peripheral is probably out of connection range of regulator – proceed according to chapter Troubleshooting.
2. In window "Add wireless station", set the name tag of the station and choose the table line where the new peripheral should be registered.
3. Upon closing the Add wireless station dialog (see Fig. "Other Settings" tab) press the Write button. The configuration will be saved in the regulator.

4. Press the Wireless outputs button to switch to view to the settings for wireless outputs (WLS). On the "Output settings" tab, assign to the logic output WLS the configured wireless peripheral by using the Station and Device fields. Test with Test button, respective output on the peripheral should respond. If it does not, proceed according to Chapter Troubleshooting.
5. In case of usage of more wireless peripherals, repeat this procedure from point one for each one. Do not connect new stations to power line at the same moment, because otherwise the identification of new station will be impossible.

FINISHING THE CONFIGURATION

After setting up the device according on previous chapters, the regulator is fully configured. You may save the preset configuration by pressing the Save button or you may load it at any time by pressing the Open button. This way you may create several different configurations and monitor them for some time and determine which one provides better utilization of energy self-consumption in your facility or household.

After you have completed the settings then in case of manipulating within the distribution box turn off entire distribution box, remove the USB cable and turn on the distribution box again.

Tip: *In order to maintain continuous monitoring the regulator can be kept connected via USB. If you want to use permanent USB connection, then it is recommended using a suitable USB isolator or USB connection extender via Ethernet (for example Silex 3000GB).*

DESCRIPTION OF WATTCONFIG ECO ITEMS

This chapter contains a list of all items available in the WATTconfig ECO control software and explains their meaning.

MAIN WINDOW

The main window displays all basic measured values and statuses. Regulator can be configured using configuration tabs.

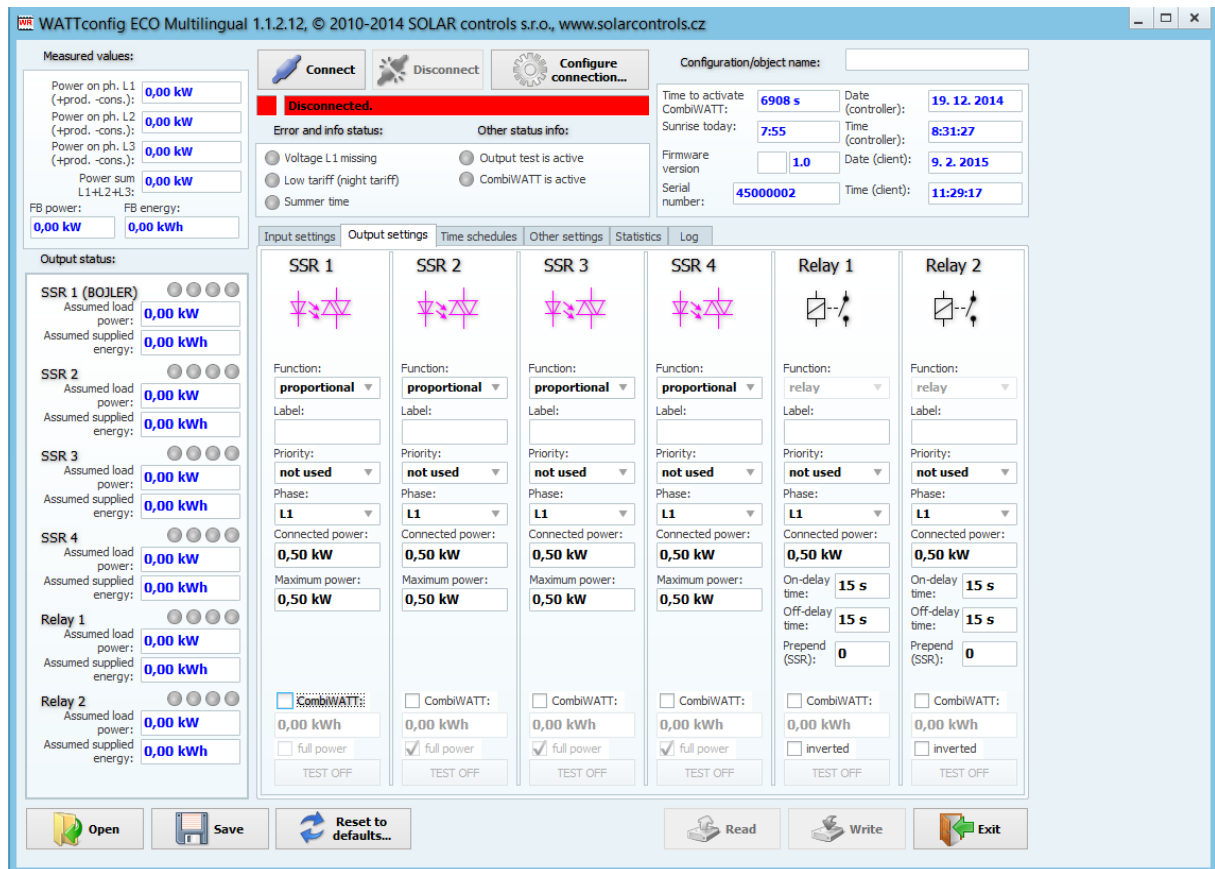

Figure 7: Main window of WATTconfig ECO software.

MEASURED PARAMETERS AND STATUSES

Measured values:

- Power on ph. L... - the actual value of the active power measured on the relevant phase wire. Positive value means production (PV-plant supplies power to the grid); negative value means that power is being drawn from the grid.
- Power sum L1+L2+L3 – sum of active power outputs in all three phases.
- FB power- presents electric power, which is registered by impulse input. The value is calculated by

$$\text{formula: } P[\text{kW}] = \frac{3600}{t_p[\text{s}] \cdot \text{Imp}_{\text{kWh}}}$$

Where:

P – resulting power value (this box)

t_p – period of impulses

Imp_{kWh} – pulse amount per kWh (see FB input configuration)

The measurement dynamics depends on the impulse frequency. It may be very small for small measured powers. The maximum measurable period of impulses is set to 15 seconds (at 1000 impulses per kWh it corresponds to an output of 0.24 kW). If the measured power is lower, zero is displayed.

- FB energy – presents electrical energy, which is counted by pulse input. The value is calculated by

$$\text{formula: } E[\text{kWh}] = E_p[\text{kWh}] + \frac{\text{Imp}}{\text{Imp}_{\text{kWh}}}$$

Where:

E - resulting energy value (this box)

E_p – initial energy input (see. FB input configuration)

Imp – pulse amount registered by FB input from the connection point. This counters are not listed anywhere.

Imp_{kWh} – pulse amount per kWh (see FB input configuration)

Impulses are counted only if the regulator is operating. It is only an auxiliary and informative feature of the regulator. Counted impulses are saved in the internal EEPROM memory every hour. In case of a short time power supply failure these values should not be very different from the actual reality. More frequent impulse saving is not possible due to technical reasons. If these values do not correspond with the value shown on the display of the connected energy meter, modify the field "Energy starting offset at input FB" to match the value of the energy meter, check the "zeroize"-field and press the Write button.

Output statuses:

- Assumed load power... - the assumed power drawn by the load connected to the relevant output. It refers to an estimated power based on the output settings and may not correspond with the actual power output of the load, as the power drawn by the connected load is not measured.
- Assumed supplied energy - daily energy counters measuring power already supplied to the relevant output. It refers to an estimated energy supplied to the load, which is based on the output settings

and may not correspond with the actual amount of the power supplied to the load, as the power drawn by the connected load is not measured. Energy counters inform CombiWATT mode or the corresponding time schedule about the energy already delivered to the load and at the same time, they also inform the user about the amount of delivered energy. Counters are reset to zero based on the configuration of "CombiWATT - Energy counter reset"-field in the Other settings tab. WATTrouter device does not know the status of the load and therefore, counters may also show much higher energy values than those actually delivered to the load (for example, if the boiler is heated up during the day and turned off by the thermostat).

- Status output indicators - inform the user about the reason for switching, or possibly about the reason for output restriction. There are 4 indicators:
 - a) Blue - it is displayed only if the output is switched on due to basic control process according to the available surplus energy from PV-plant. This indicator also signals possible off-delay time for the relay output (after being enforced by time schedule or CombiWATT mode).
 - b) Violet - it is displayed only if the output is switched on by the CombiWATT mode.
 - c) Green - it is displayed only if switching is enforced by time schedule.
 - d) Red - it is displayed if the output is restricted by time schedule.

Other statuses:

- Time to activate CombiWATT – it displays the remaining time before activation of the CombiWATT mode. The value is equal to the "CombiWATT delay time"-parameter, provided that some surplus energy is still detected. If the value equals to zero and low tariff signal is detected at the same time, the system activates the CombiWATT mode for corresponding outputs.
- Sunrise today – it displays time of sunrise for today. This time is calculated directly in the regulator based on the actual calendar date and the actual geographic location of the facility/building (see "Geographic location" on the "Other settings" tab). The calculated time is converted to the current local time based on configuration of the "Use summertime" and "Time zone" settings. The official sunrise zenith, 90° 50' is used. Sunrise time is used to reset energy counters ("Assumed supplied energy"-fields) in the main window, provided that the applicable mode in the field "CombiWATT – Energy counter reset" is selected.
- Firmware version – displays actual regulator firmware version.
- Serial number- displays serial number and it is unique for each regulator.
- Date (regulator) – it indicates the real time running inside the regulator (date part).
- Time (regulator) – it indicates the real time running inside the regulator (time part).

Note: Regulator real time is backed up with a built-in lithium battery, so it runs even if the regulator power supply is turned off.

- Date (client) – it displays the real-time running on the PC (date part).
- Time (client) – it displays the real-time running on the PC (time part).

Error and info status (gray in inactive status, red in active status):

- Voltage L1 missing – no voltage was detected on phase L1 - this is a hardware error of the regulator and the regulator must be replaced or repaired.
- Low tariff – if the low tariff signal is detected the red light comes on, otherwise is grayed.

- Summer time - informs the user that the summer time mode is active. Summer time starts at 2:00 CET, on the last Sunday in March and ends at 3:00 CEST, on the last Sunday in October. If the option "Use summer time" is not marked on the "Other settings" tab, the indicator remains inactive.
- CombiWATT is active – informs the user that CombiWATT mode is active. This indicator is active if the condition necessary to run CombiWATT is valid, if the low tariff is active and if the CombiWATT function has been configured for some output.
- Output test is active – informs the user about a status when some of the outputs have been activated by the TEST button.

INPUT SETTINGS TAB

In this tab you may set measuring inputs, FB input and control mode.

Measuring output and control mode:

- Control settings - it is used to set the control mode:
 - a. Sum of all phases - the regulator will control all outputs according to the sum of measured active powers from all three phases. In this mode it is not necessary to set phases for individual outputs as this does not matter.
 - b. Each phase independently - the regulator will control outputs according to measured active power on each phase wire separately. In this mode it is necessary to correctly set phases for all active outputs. They must correspond with the wire where the corresponding load is connected to.
- Phase order settings - it is used to set the phase sequence (order) based on the fact how wires are actually passing through the current sensing module. Phase sequence is set only for I_L2 and I_L3 inputs (phase current measured at the I_L1 input must always match the phase connected to L1):
 - a. L1, L2, L3 – original phase sequence setting.
 - b. L1, L3, L2 – reverse phase sequence setting.
- Ratio for external CTs - set this ratio only if you use additional external current transformers (CTs), whose secondary coils are shorted with a wire passing through measuring coils of the current sensing module. If you use standard connection for WATTrouter device that is, the facility or household supply wire is passing directly through measuring coils, then this ratio should be 1:1. It is possible to adjust the measuring accuracy of the current sensing module by means of this ratio. External current transformers can extend the measuring range of the regulator up to any value, depending on the conversion rate of the external current transformer.

Example: Let us say you want to use WATTrouter ECO in a facility where the main circuit breaker is rated up to 3x400A. In this case you have to buy external current transformers with ratio 400A:5A. Connect/short-cut their secondary terminals using a wire, and at the same time, pass it through measuring coils of the current sensing module (see figure 7). Now set the conversion rate to 400:5.

However, in order to use the full range of the built-in A/D converter, it is recommended to make 4 turns around the measuring coils to get optimum conversion rate of 400A:20A. Then, set the conversion rate to 400:20.

Caution: Use only external CTs for large facilities and large PV-plant power outputs. If you are using a high conversion ratio of external CTs, you have to take into account that (relatively) small power outputs (in the example describing the optimized conversion rate 400A:20A, the limit represents

approximately 0.75 kW per phase) are below the resolution capacity of the measuring inputs and therefore, these power values will not be measured and equal to zero.

- Current orientation Lx - it is used to change the sign of measured powers, if the current sensing module is fitted in reverse position, or in cases for example, when it is desirable to pass the wire through the module in reverse direction.

FB Input configuration

- Energy starting offset at input FB - this field can be used to set initial values of measured energies. If the values of measured energies do not match the display on the connected energy meter (for example), put the value of the energy shown on the display into this column and reset impulse counters to zero by marking the option "zeroize".
- Zeroize - used to reset impulse counters to zero.
- Number of impulses per one kWh – FB input – this column is used to set the number of impulses per one kWh. Set the value according to the label or manual of the connected energy meter, inverter or according to another compatible measuring instrument. It is recommended to use highest possible amount of impulses per kWh to get better resolution for the FB power field.
- Data source – use this to setup the energy data source for the FB input. In current firmware revision this assignment is used only to generate statistics about production. Following options are available:
 - a. Other – input counts e.g. energy flowing to a load or another appliance.
 - b. Prod. L1 – input counts energy measured on L1, value will be added to daily production stats on L1.
 - c. Prod. L2 – input counts energy measured on L2, value will be added to daily production stats on L2.
 - d. Prod. L3 – input counts energy measured on L3, value will be added to daily production stats on L3.
 - e. Prod. L1+L2 – input counts energy measured on L1+L2, value will be equally divided to daily production stats on L1 and L2.
 - f. Prod. L2+L3 – input counts energy measured on L2+L3, value will be equally divided to daily production stats on L2 and L3.
 - g. Prod. L1+L3 – input counts energy measured on L1+L3, value will be equally divided to daily production stats on L1 and L3.
 - h. Prod. L1+L2+L3 – input counts energy measured on all phases, value will be equally divided to daily production stats on L1, L2 and L3 (i.e. counted value will be divided by 3).

Note: In case the inverter does not divide produced energy equally to each phase it is necessary to use separate measurement on each phase, but WATTconfig ECO will display only one as only one FB input is available.

OUTPUT SETTINGS TAB

On this tab you may set basic parameters for outputs and setup the CombiWATT mode for outputs.

- Station – specifies the wireless station – terminal device. Available only at WLS outputs that can be activated after inserting the SC-Gateway to the controller
- Device index – specifies the output on the wireless station - terminal device. Available only at WLS outputs that can be activated after inserting the SC-Gateway to the controller.

- Function - used to set the functionality of the corresponding output:
 - a. Relay- the output will operate in On/Off mode (as a relay).
 - b. Proportional - the output will operate in proportional regulation mode, by modulating connected load's power according to the available surplus energy.
 - c. PWM – (only for SSR outputs with activated SW package PWM mode for outputs) the output will operate in proportional regulation mode, by modulating connected load's power according to the available surplus energy, but the output of assigned regulator will be sent as PWM, see technical specification for PWM parameters.



Caution: This mode is only suitable to control the output power of external devices (such as some battery chargers and heat pumps) which are equipped with this kind control input. This mode cannot be used for external solid state relays!

- Label – used to assign a label for the relevant output. Label may contain a maximum of 8 characters in ASCII encoding.
- Priority – it is used to set priority for the relevant output. First priority is the highest. "Not used" means that the output is not activated. Output with higher priority will switch on "sooner" and will switch off "later" (see the chapter "Setting up main function"). If you are using the "Sum of all phases" control mode, you cannot select the same priority for two or more outputs (except for the "not used" status). In the "Each phase independently" control mode this settings must be applied to each phase. From the first (the highest) priority all the way down to the lowest priority. No gaps are allowed in the priority settings, that is, you cannot set only the 1st priority and the 3rd priority, without setting the 2nd priority as well. WATTconfig inspects priority and phase settings before writing them into the regulator.
- Phase – if using the "Each phase independently" control mode you have to set the phase wire for each output where the relevant load is connected to. The setting must correspond with the reality. Use the TEST button to verify that.
- Connected power - it specifies the active power rating of connected load. If power rating is specified in VA and the power factor $\cos(\Phi)$ is specified, you may determine the active power rating using $P[W] = S[VA] \cdot \cos(\Phi)$ formula. The connected power value should be equal to the power rating of connected load for SSR outputs, and must be higher or equal for relay outputs.
- Maximum power – this value applies only for SSR outputs. It determines the maximum allowed power applicable for the connected load. In many cases this value is equal to the connected power value, but for example, due to limited SSR cooling possibility or due to saving the surplus energy for additional outputs, you may decrease this value. The value in the "Assumed load power"-field may be slightly lower than the selected maximum power value, even if the output is fully excited and maximum power is reached. The reason is that SSR outputs do not switch on fully proportionally but only "quasi-proportionally", which means, only in certain switching levels.
- Prepend (SSR) – fill in 1 if you want a relay with lower priority to switch on when assumed load power on nearest higher priority proportional output (SSR or more specifically, an output with preset proportional switching function or PWM) reaches the relay's "Connected power" value. Fill in 2 if you want this relay to be switched on when sum of assumed load powers on nearest 2 higher priority proportional outputs reaches the relay's "Connected power" value. The function works similar for higher values. This function will violate the preset order of priorities. However, it allows using almost all available surplus energy even if heating elements are connected to relay outputs. For example, if you are using a three-phase heating element.

Example 1: heating element 3x2 kW connected and configured in the following way:

- 1st heating coil connected to SSR No. 1, 1st priority, connected power 2 kW, maximum power 2 kW
- 2nd heating coil connected to relay No. 1, 2nd priority, connected power 2 kW, prepend value = 1
- 3rd heating coil connected to relay No.2, 3rd priority, connected power 2 kW, prepend value = 1

If the SSR No. 1 is fully switched and consumes 2 kW of surplus energy and the amount of surplus energy further increases, then the relay No. 1 will switch on and SSR No. 1 will automatically reduce its power. If the surplus energy increases by additional 2 kW so that the SSR No. 1 is fully switched again, the relay No. 2 will be switched and SSR No. 1 will again automatically reduce the power output. If the power output continues increasing, additional outputs with lower priorities will be connected. Similarly, outputs will disconnect when the PV-plant power generation will decrease.

Note: To make sure that the function works correctly, all 3 heating coils must be active (heated) at the same time or inactive (disconnected by the thermostat). The algorithm will not work correctly if heating coil No. 1 is disconnected by the thermostat and the other two heating coils will continue producing heat. In this scenario, the relay will be continuously connected and disconnected because the regulator is trying to keep "virtual zero" or "phase zero", depending on control mode, and is not able to determine from phase wire measurements that heating coil No. 1 is disconnected. The relay will switch on only if the measured power on the respective phase is stable and does not fluctuate. Otherwise the relay switching might be counterproductive.

Note: In order to ensure correct function of the algorithm it is necessary that the SSR - to which heating coil No. 1 is connected, is assigned with the higher priority than the relay No.1 with the 2nd heating coil. If heating coil No. 1 connected to SSR has lower power rating than the other two remaining heating coils, relays will connect only after the overall power (power drawn by the first heating coil + surplus energy) exceeds the value of "Connected power" field set for relay No. 1. In this case, the part of surplus energy will be still delivered to public grid as in the case of the default function of WATTrouter controller.

Example 2: A boiler and 2 other heating elements:

- Boiler connected to SSR No. 1, 1st priority, connected power 2 kW, maximum power 2 kW,
 - 1st heating coil connected to SSR No. 2, 2nd priority, connected power 2 kW, maximum power 2 kW,
 - 2nd heating coil connected to relay No. 1, 3rd priority, connected power 2 kW,
 - a) Prepend value set to **0**: In this case the 2nd heating coil will never be prepended and after 4kW surplus is reached and consumed by boiler and 1st heating coil the controller will wait until the total available surplus is 6kW. Then it connects 2nd heating coil. In the meantime surplus flows to public grid.
 - b) Prepend value set to **1**: In order to prioritize the 2nd heating coil, we will take into account only the assumed load power of the 1st heating coil, which means that the boiler will always have first priority. So after total surplus reaches 4 kW the 2nd heating coil will be connected (prepended) before the 1st heating coil.
 - c) Prepend value set to **2 and higher**: In order to prioritize the 2nd heating coil, we will take into account the sum of assumed load powers of the boiler and 1st heating coil. So after total surplus reaches 2 kW the 2nd heating coil will be connected (prepended) before boiler and 1st heating coil.
- Minimum power – for SSR outputs when PWM function is used this value gives the minimum power for the connected load. The output will not be activated unless available surplus energy exceeds this threshold. Nonzero value can be useful e.g. for proportional control of inverter air conditioner or heat

pump. These devices usually don't run with less than 1/3 of nominal power. For more information about controlling air conditioners or heat pumps proportionally see manufacturer's web site.

- PWM-I – for SSR outputs when PWM function is used then this value is equal to the I-component value of the regulator assigned to this output. The value can be selected between 1 and 1000. Select value according to the dynamics of the connected system (battery charger, heat pump etc.). Start with a small value (1 to 10) and gradually increase the value if the system dynamics is slow. For values less than 100 the dynamics is rather slow so that the system will enable to switch outputs with lower priorities, to cover available surplus energy. If the Minimum power field is nonzero the control will start after 3 minutes. In the meantime minimum power is held – aimed for soft-starts of air conditioners or heat pumps.



Caution: In case of a too big PWM-I value the system may become unstable and this status may damage the connected device, when there is no built-in protection in the device!

- Delay - for SSR outputs when PWM function is used this value gives the switch off delay for case air conditioner or heat pump is connected to this output and controlled by PWM mode. If there is not enough surplus energy to run the device anymore the device will continue to run at minimum power for specified amount of time.
- On-delay time – this value applies only for relay outputs. This delay time runs from the moment a condition has been detected to switch the relay output on. After the time elapses the relay is really switched on. It is recommended to use the default value, or to slightly increase it if the relevant load cannot be switched on frequently. The value may be decreased down to 2s. However, such small delay time may sometimes cause false load switching. Therefore, we recommend decreasing the value only in certain cases and after proper testing. This time delay is not active in CombiWATT mode.
- Switch-off delay - this value applies only for relay outputs. This delay time runs from the moment a condition has been detected to switch the relay output off. After the time elapses the relay is really switched off. This feature is necessary for loads which cannot be switched on frequently. The value may be reduced down to 2s. For example, for heat pumps we recommend increasing this value significantly. This time delay is not active in CombiWATT mode. Here it is assumed that the low tariff activity time is always sufficiently long in case of double tariff rates.
- CombiWATT – activates the CombiWATT mode for the relevant output (output must be activated, i.e. to have assigned valid priority). Enter the required amount of energy power, which must be supplied to the corresponding load every day.
- Full power – mark this field if you want to switch the SSR in CombiWATT at full power, regardless of the Maximum power setting ("Maximum power"-field). In this way you may eliminate the occurrence of disturbing "flicker effect" produced by light bulbs or fluorescent tubes. If you don't check this field the specified maximum power for the load is used in CombiWATT mode.
- Inverted – if checked, the selected output will be switched on in inactive status and switched off in active status. The output will not be switched on if any defect/failure is detected, or the output was not assigned with any priority, or the output was not assigned with relay function. In these cases, the output inversion condition does not apply. For example, this feature may apply if there is necessary to "unlock" some device according to available surplus energy.

This function can be useful when you want to avoid delivering surplus energy to public grid. Here, typically, one relay output is set as inverted and assigned to last priority. And it is used to block the

inverter. If there is inconsumable surplus energy (typically in hot summer) this relay output disconnects the inverter for some time (given by Off-Delay time). After this time the inverter starts again. To block the inverter it is recommended to use analog inputs of the inverter (for inverters which support power reduction). In this configuration the inverter will be disconnected from grid on each WATTrouter failure or when WATTrouter itself gets disconnected from grid.

Example: Configure the maximal power limiter of PV plant on waste heating coils.

Task: 3phase PV plant cannot exceed total power of 60kW. Measured by electricity provider in quarter hour intervals.

The Power offset in Expert settings will be set on maximal value 20kW of PV plant in each phase. Heating coils and inverted output will be connected as follows:

- SSR No. 1, 1st priority, Connected power of waste heating coil 2 kW, Maximum power 2 kW,
- SSR No. 2, 2nd priority, Connected power of waste heating coil 2 kW, Maximum power 2 kW,
- SSR No. 3, 3rd priority, Connected power of waste heating coil 2 kW, Maximum power 2 kW,
- Relay No. 1, 4th priority, Connected power 0,05kW, On-delay time set on 15s, Off-delay time set on 120s.

As an inverted output will be set just the Relay 1, so the operation of “excess” inverters will be dependent on this relay. In case of fault on waste heating coils and surplus energy rises above the permissible limit or there is a fault in the controller or the controller gets disconnected from the network, etc., this relay opens, thereby also disconnecting the “excess” inverters. These "excess" inverters therefore produce energy without risk of exceeding the maximum allowed performance of the PV-plant.

The function also finds application when it is necessary to avoid excess energy flow into the grid, as much as possible. The inverter operation is again dependent on relay output with the lowest priority and Inverted field for this relay output is checked. Off time delay is set by Off-delay time. To block the inverter operation it is advised to use the analog inputs of the inverter that support power limitation (typically German inverters). The inverter disconnects in this configuration, even if a fault is detected on WATTrouter or if you disconnect the power from WATTrouter.

- TEST – it is used to test the relevant output and load. If you press any of the TEST buttons, all other control functions regarding the outputs are blocked.

TIME SCHEDULES TAB

On this tab you may set time schedules for individual outputs.

Up to 2 independent time intervals may be set for each individual output. During these time intervals the relevant output may be forced to be switched on, or the switching process may be restricted. Enforcing or restricting may be further conditioned by the presence of the low tariff signal and / or by the status of daily energy counters for the relevant output (field "Assumed supplied energy").

You may use time schedules to create more complex configurations for outputs, based on user preferences. You may also use time schedules to add or possibly replace the built-in CombiWATT mode.



Time schedules operate independently of the basic regulation mode. If used inappropriately, time schedules may worsen the energy efficiency of your facility. Setting up time schedules depends entirely on your creativity and provides a wide range of different combinations. Only advanced users should use time schedules and only after they have been thoroughly familiarized with the applicable functionalities of this device!

Description of a time schedule option:

- Time schedule mode:
 - a) Not used – time schedule is not active.
 - b) Restricted – the output will be restricted during the interval specified in the "From - To" field. If the "From" time is larger than the "To" time, the restrictions or limitations are valid from the "From" time to midnight and on the next following day from midnight to the "To" time.

Restriction applies to all activities of this output and has the highest priority. During the time interval neither basic regulation - based on the surplus energy - nor the CombiWATT mode will work. Neither any other time schedule set to enforced mode will work. Output restriction does not prevent outputs with lower priorities from working regularly.
 - c) Enforced - the output will be enforced/switched-on during the time specified in the "From – To" interval. If the "From" time is larger than the "To" time, the enforcement is valid from the "From" time to midnight and on the next following day from midnight to the "To" time. **Enforcement has the second highest priority** and it may be disabled only with another time schedule set to the restricted mode at the same time. During the preset time interval the output enforcement deactivates the basic regulation mode based on surplus energy. However, it does not affect conditions for the activation of CombiWATT mode, which then can run simultaneously with the enforcement mode. Output enforcement does not prevent outputs with lower priorities from working regularly.
- From – time when time schedule begins
- To – time when time schedule ends
- LT – If you mark this field, the time schedule additionally requires the existence of the low tariff signal to become active. This function differs based on the time schedule mode, and it is primarily based on the fact that electric power in low tariff is cheaper than electric power in regular (peak) tariff:
 - a) Restricted mode – the output is restricted only if low tariff is not active.
 - b) Enforced mode – the output is enforced only if low tariff is active.
- Energy – if you mark this field, the time schedule activity additionally depends on the status of the daily energy counter of the relevant output (the "Assumed supplied energy" field). Again the function differs based on the time schedule mode:
 - a) Restricted mode – the output will be restricted only if the daily energy counter exceeds the value specified in the Limit field.
 - b) Enforced mode – the output will be enforced only if the daily energy counter did not yet reach the value specified in the Limit field.

Tip: Time schedules may also be set for an output which does not have any assigned priority. These outputs may be used for example, as time switch clock etc. Labels and "Connected power" field may be configured for these outputs using the Output settings tab. "Connected power" field of such output is then used to update the daily energy counter.

Note: Impact-free transition to the basic regulation mode: If the condition necessary for the enforcement of a relay output no longer exists, a basic 10s delay is set for this output. This delay is used to ensure impact-free transition to the basic regulation mode. Similar method is also used for SSR outputs.

For more practical samples demonstrating configuration of time schedules, see the chapter Configuration examples.

OTHER SETTINGS TAB

On this tab you may set other advanced device settings.

Expert settings:

- Power offset – this field specifies the difference between the actual sum of measured powers in 3 phases L1+L2+L3 and the value used for the control purposes. For example, if the actual sum of measured powers L1+L2+L3 equals to +500W and the power offset equals to -100W, the regulator will use the value of 400W to determine the conditions for output switching. Above terms apply for the "sum of all phases" control mode. For the "each phase independently" control mode this power offset value applies for each phase independently. The lower (more negative) the power offset is, the more power consumption from grid is avoided in transitional statuses as well as in stable statuses where the SSR switch only small amount of power to the load. Transitional statuses are usually identified by 4-quadrant energy meters as "movement around zero", where production and consumption indicators change irregularly and fast. Negative power offset avoid showing up the consumption indicator, but during normal and stable control statuses some surplus energy flows unused into public grid. If you use standard connection and configuration, then it is not recommended to use positive offset.
- CombiWATT delay time – specifies the time delay from the moment where PV-plant production is not detected anymore (after sunset) until CombiWATT can become active. It is recommended to increase the setting if you are frequently using electrical loads (other loads than those connected to the regulator), which consume entire surplus energy of the PV-plant for long time. In this case, the regulator cannot recognize that PV-plant production is not yet over.
- CombiWATT production limit – small amount of active production or surplus energy (single units or tens of Watts) may be detected for facilities with significant capacity loads (blocking capacitors, UPS stations, large number of switching sources, etc.), even though the inverter does not work. The cause may be even the inverter itself. In this case, the regulator displays small amounts of positive active power in either phase wire. Reason for this is significant reactive power, which is drawn by those devices and measured by WATTrouter near the "recognition line" between production and consumption. Also watt meters produced by different manufacturers behave in similar way. This item partially tries to resolve this issue by setting additional offset valid for each phase wire.

For example, if the production limit equals to 0.1 kW, CombiWATT mode will already be initiated (provided that also other requirements for the initiation of this mode are met), even if the production falls below 0.1kW in each phase.

- CombiWATT – Energy counter reset – this field is used to reset energy counters, which represent the reset of the "Assumed supplied energy"-fields in the main window. You have two options:
 - a) At sunrise: counters are reset if the time equals the sunrise time valid for this day.
 - b) At fixed time: counters are reset if the time is the same as the time set in the field called "Fixed time for energy reset".
- Fixed time of energy reset – it specifies a fixed time for energy counter reset mode according to fixed time (the previous paragraph, mode b).

Other settings:

- Synchronize date and time with the client - check this field if you want to synchronize the regulator date and time with the actual time running in your PC.
- Use summer time - check this field if you want the regulator to perform automatic switching between summer and winter time. Based on EU recommendations only summertime is supported, which starts at 2:00 CET on the last Sunday in March and ends at 3:00 CEST on the last Sunday in October. The summertime information is used to automatically modify the current time as well as the calculated sunrise time.

- Time zone - specify the time zone based on your country. The default value uses Central European time. This value is only used to modify the calculated sunrise time. Time zones outside of multiples of full hours are not supported.
- Latitude - enter the latitude (in degrees) here. The value is used to calculate the sunrise time and therefore, values specified in degrees are precise enough.
- Longitude - enter the longitude (in degrees) here. The value is used to calculate the sunrise time and therefore, values specified in degrees are precise enough.

Tip: By shifting the geographical longitude, the sunrise time can be adjusted, so the energy counters can be reset up to your demands. For example it can depend on the PV-plant angle and direction. If you are not sure with setting, do not adjust it. Default geographical location is located in Central Europe.

WATTconfig settings:

- Language - select the language which you want the WATTconfig ECO software to use after restart. The Custom item may be used for any other, still not supported language. If you want to use this option, you have to manually translate strings in the *custom.xml* file into the language you want to use.
- Reset unit on configuration write - check this field if you want to restart the regulator after each configuration was written. Regulator reset is necessary to delete daily energy counters, etc.
- Default tab - Set the tab in the WATTconfig you wish to appear when you launch the program. This setting is stored by WATTconfig software on PC hard drive.

Table of wireless stations:

Note: This function is only accessible once the SC-Gateway is inserted.

- MAC address- in this field the MAC address of connected wireless device is listed
- Name tag- in this field, the wireless devices can be labeled. The label is displayed in drop-down box at the station field of WLS wireless outputs.

Buttons:

- Update firmware button - allows you to update firmware of this product. Updates are freely accessible in Download section at manufacturer's web pages. If there is an update available you may download it and install it. The progress of the update process is indicated on screen and it takes about up to 60 seconds.



Update of original firmware is completely safe. The system fully and thoroughly inspects the integrity of the update file, as well as the integrity of data after downloading. In case of a power failure during the update, you may download the firmware again at any time after your power is restored. Should you experience an unsuccessful firmware update repeatedly, you may file a claim pursuant to valid trade terms and conditions. It is strictly prohibited to modify the downloaded file in any way. If you modify the downloaded file and even if the system inspected the integrity, you may still damage your product and lose your warranty!

- Buy additional features- display dialog with the same name, where you can purchase optional SW features and activated them in regulator. For more details, see chapter "Buy additional features" window.

STATISTICS TAB

Note: This function is only accessible with activated Statistics SW feature.

This tab displays daily, weekly, monthly and yearly statistics on production, consumption and surplus (excess) energy. Statistics can be exported to *.csv files.

Caution: Through current sensing module you can obtain only the consumption and surplus (excess) energy. To display data on production and self-consumption, it is necessary to connect a pulse output from an external meter to FB input, which measures the power of the inverter. Alternatively, connect inverter directly to the FB input when the inverter is equipped with a compatible pulse output. It is also necessary to configure the FB input in the "Data Source" field on the Settings tab, in order to let the regulator process the counted value properly.

Caution: Values are approximate! The device does not know the exact values from utility/billing meters!

Caution: Daily statistics are reset every time just after midnight, i.e. at 0:00 A.M. At the same time, daily values from the just finished day are moved into history. When you change the date in the regulator you may cause irreversible deletion of stored history!

Daily statistics:

- Phase Lx—displays information about the surplus (excess) energy, normal and low price energy tariff as well as (optionally) production, when counted with a FB input, in the current or selected day.
- Total L1+L2+L3 – displays summary data from all three phases. The calculation of these data depends on the selected control mode -the "Control settings" field on the "Input settings" tab:
 - a. Each phase independently – summary data are simply the sum of the fields from all 3 phases
 - b. Sum of all phases – summary data are updated continuously from immediate results. **In this control mode summary data are not the simple sum of the displayed values in each phase** (in one phase the surplus energy may cover consumption in different phase, etc.).
- Daily output status- displays the assumed amount of energy supplied to each load in the current or selected day. **Since the statistics are reset every time just after midnight, these values do not correspond with the values in the fields "Assumed supplied energy"**(reset of those fields is generally done at different time).
- Daily FB input status- displays the measured energy at corresponding FB input in the current or selected day. If the FB input is configured to measure production then a short label "counts prod." appears above the measured value.
- Show for day –select the date for which to view daily statistics. You can display them for current date and last 7 days.
- Erase—use this button to delete all statistics. Confirmation dialog will be shown first.
- Charts – they show a graphical interpretation of the daily statistics on production and consumption. Charts in each phase indicate the part of corresponding summary data (pie slice or part of the bar). The self-consumption value is calculated from the relationship: self-consumption = production – surplus energy. Self-consumption values are not available unless the displayed production value is bigger than measured surplus energy value.

Note: For very small energy values (typically immediately after resetting statistics after midnight) internal rounding to 0.01kWh is significant for displaying the charts .In these cases, pie charts may not be displayed absolutely correctly.

Weekly statistics:

- Chart -shows the 5 main summary data (production, surplus energy, self-consumption, consumption in normal and low tariff) in bars for the last 7 days. Double click on the bar to view the day in the daily statistics.
- Export -exports the weekly statistics to a *.csv file that can be opened e.g. in MS-Excel.

Monthly statistics:

- Production chart - displays summary data on production (production +surplus energy) in the last 31 days.
- Consumption chart - displays summary data on consumption (self-consumption, consumption in normal and low tariff) in the last 31 days.
- Export- exports monthly statistics to a *.csv file that can be opened e.g. in MS-Excel.

Note: The monthly statistics can't show detail of a day as in the case of weekly statistics, details are stored only for the last 7 days.

Yearly statistics:

- Production chart – displays summary data on production (production +surplus energy) in the last 12 months.
- Consumption chart – displays summary data on consumption (self-consumption, consumption in normal and low tariff) in the last 12 months.
- Export- exports yearly statistics to a *.csv file that can be opened e.g. in MS-Excel. Exports data for last 24 months.

Note: Actual day will take effect in the annual history (current month) after moving into history (after midnight).

LOG TAB

This tab displays error and warning log. For example, the system displays detected communication errors. Infrequent occurrence of errors is normal, is caused by communication disturbance on line and does not indicate device damage.

OPTIONS AND BUTTONS

Main window buttons:

- Connect – connects your computer to the regulator and loads configuration from the regulator just after successful connection has been established.
- Disconnect - disconnects your computer from the regulator.
- Configure connection - the software displays a window where you may configure active connection.
- Open - loads configuration from PC.
- Save - saves configuration to PC.
- Reset to defaults – loads default configuration settings.
- Wireless/Built-in outputs – this button is only available when SC-Gateway is present in the controller. It allows to switch software interface to WLS wireless outputs and back to built-in outputs.
- Read – reads configuration from the regulator.
- Write – writes (downloads) configuration to the regulator and optionally resets the regulator.
- Exit - exits WATTconfig ECO software.
- Configuration/object name - it is used to set label to the facility or the current configuration. Text may contain maximum of 16 characters in ASCII encoding.

SERIAL PORT DRIVER CONFIGURATION WINDOW

In this dialog box you may specify USB interface parameters.

Port settings:

- Port – if the USB driver correctly installed, you can find appropriate port COMx in drop – down menu. If several or no ports are shown, check installation correctness of USB port in Windows device manager. You can also find out there which port is used for this communication.
- Remaining items can be used to set communication parameters. Valid values are: Data bits =8, Stop bits=1, Baud rate =38400 Bd, Parity – none.

Timeouts:

- Default read timeout – total time necessary to receive response from the regulator. Modify the value (increase) only if you experience communication problems.
- Default inter-byte timeout - time necessary to accept individual bytes from regulator. Modify the value only if you experience communication problems.

Buttons:

- Default – sets default communication parameters.
- OK, Cancel – standard confirmation and cancellation of the dialog box.

BUY ADDITIONAL FEATURES WINDOW

In this dialog box you may buy and activate additional (optional) software features.

- Additional features – shows available SW features including the price. In case of not listing the price, regulator is missing internet connection or manufacturer's web is not accessible. In this case, you can continue neither in shopping nor in activation process of optional software features.
- User account login – is for signing in the personal profile created by customer at the producer web pages.
- Order – by this button you will create the order of selected SW features at the manufacturer's web pages. You will be redirected to web pages where you will be able to complete the order.
- Activate – once the order is paid and processed, you can activate your SW features in your controller.

Complete the ordering and activation:

Caution: This procedure is necessary to be performed with one PC (notebook) and with the same instance of the software WATTconfig ECO. The PC must be free from any custom HTTP restriction or other user restrictions that would impede the connection of the software to the Internet and storage of temporary values to the hard disk. In case of problems, consult an expert in IT. Additional software features are bound to the serial number of the controller and they must be activated directly in the controller after purchase.

1. Connect your PC to regulator for a while, so its serial number can be detected.
2. Then get connected to Internet.
3. Fill in your access data to personal profile at the manufacturer's web pages (if you are not having personal profile yet, create it at the web pages of the manufacturer), mark required software features by checkboxes and then press button Order.
4. Once everything is OK, then new order is created at the manufacturer's website, which needs to be confirmed at this website. Then make a payment based on prepayment invoice which will be sent to you by email.
5. Wait till final invoice will arrive to you by email. This may take couple of days, based on selected way of payment.
6. Open this dialog again, fill in your access data for your profile at the manufacturer's website and press button Activate. You need to use the same profile for activation as you used for purchase of additional software features.
7. If everything is correct, get connected to controller. Activation of purchased additional features will be done automatically. If the activation fails and purchased features are not available, you can repeat activation (point 6 and 7) at any time, or contact the manufacturer's technical support.

SC-GATEWAY MODULE STATUS

Module status	Behavior after power on	Note
Module has no assigned (bonded) wireless peripherals.	1. Both LED ON for 1 sec, OFF for 1 sec	Successful module initialization.
	2. Both LED synchronously blinking with period of 1 Hz for 10 sec	Time window for assigning (bonding) new wireless peripheral.
	3. Both LED OFF.	Sleep mode.
Module has assigned (bonded) at least one wireless peripheral.	1. Both LED ON for 1 sec, OFF for 1 sec	Successful module initialization.
	2. LED LINK blinking with period of 100 ms on each data transfer, LED PWR flashes for 100 ms each 2 sec	Communication running between module and wireless peripherals.
Module not installed or damaged.	1. Both LED off after power on.	Check correct placement of the module inside of the controller or contact service support.

LED STATUSES

The following table shows possible regulator statuses indicated by built-in LEDs.

LED	Status	Note
LED PWR (green)	On	The regulator is switched on and no output is active.
	Flashes	The regulator is switched on and some outputs are active.
	Flashes quickly	The regulator is switched on and boot mode is active.
	Off	The regulator is without power supply or there is a failure.
LED COM (yellow)	Off	Communication with computer via USB was not established.
	Stays on or flashes quickly	Communication with computer via USB was established.
LED ERR (red)	Off	No error status detected.
	Flashes regularly in the following way: short- short- short	L1 voltage is missing. Proceed according to instructions specified in the chapter Description of WATTconfig ECO items.
LED OUT	Off	The relevant output is not active.
	On or flashes quickly	The output is active (switched on)
LED PWR (blue) under the lid of regulator.	See chapter. SC-Gateway module status	
LED LINK (yellow) under the lid of regulator.	See chapter. SC-Gateway module status	

CONFIGURATION EXAMPLES

These examples only demonstrate the potential use of the device - in most cases however, settings must be modified.

EXAMPLE NO. 1 – ONE LOAD ONLY

Boiler with nominal power rating of 2 kW, 200l of water, average cold water temperature at the input is 12 °C, warm water target temperature 50 °C, average daily water consumption is 160 l. The daily amount of electric power necessary to heat up the entire boiler (without taking into account heat losses) is:

$$E = \frac{c_v * V[l] * \Delta T[K]}{3600000} = \frac{4180 * 200 * 38}{3600000} = 8.82 \text{ kWh}$$

Average daily losses of boilers with these parameters represent approximately 1.5 kWh. If you use 160 l of warm water and you take into account heat losses, the daily supply of electric power is approximately 8.6 kWh.

Boiler is connected to SSR output No. 1, WATTrouter ECO device uses low tariff signal and the boiler operates under CombiWATT mode.

The time schedule is configured for the boiler between 15:00 and 19:00. It becomes active only if the low tariff is available. This allows you to heat up water for evening use, provided that during morning and afternoon hours the boiler was not sufficiently heated up by power supplied by the PV-plant. If low tariff is not active, the basic control mode according to available surplus energy continues even during this time period.

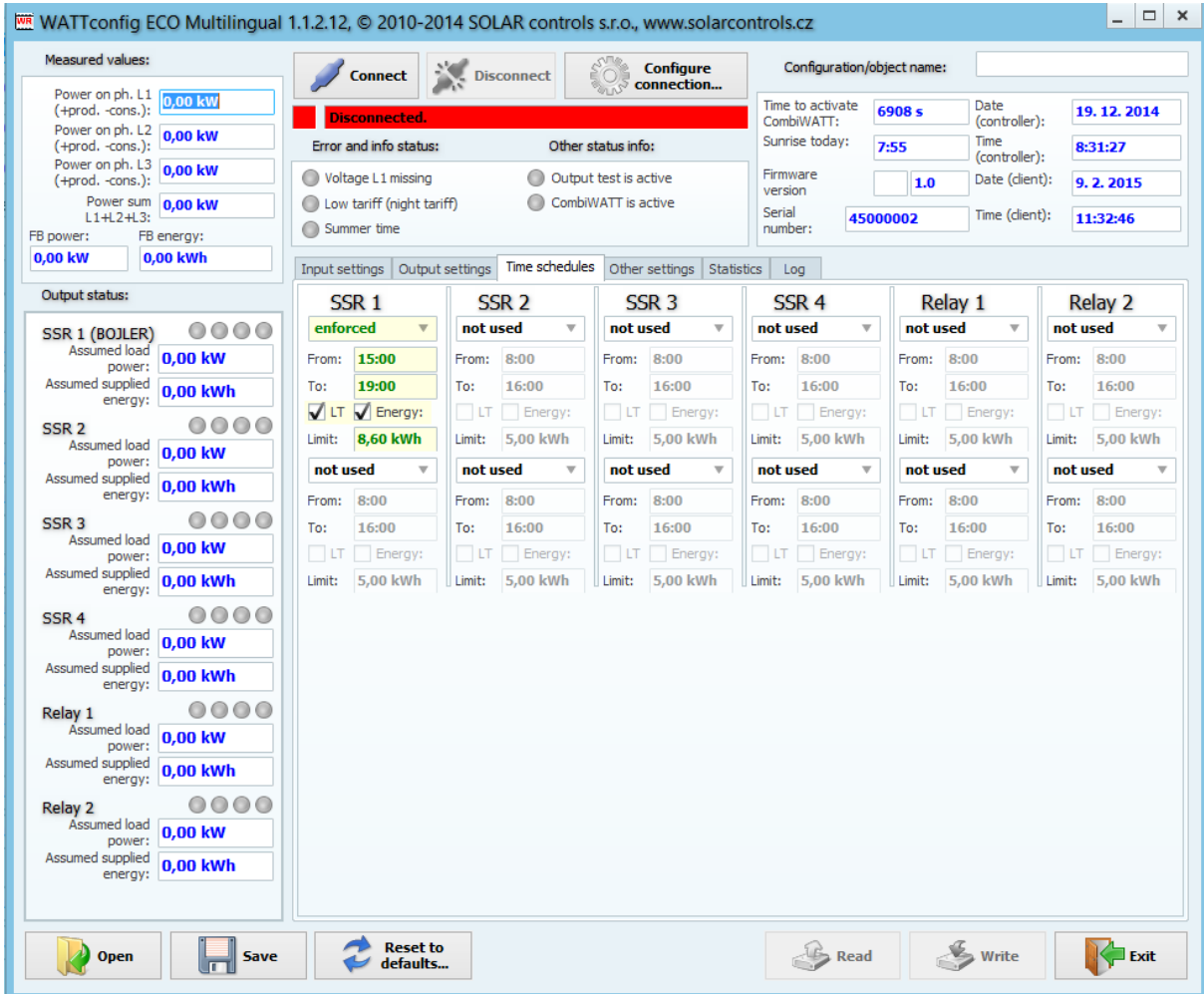

The screenshot shows the 'WATTconfig ECO Multilingual 1.1.2.12' software interface. The main window is titled 'WATTconfig ECO Multilingual 1.1.2.12, © 2010-2014 SOLAR controls s.r.o., www.solarcontrols.cz'. The interface is divided into several sections:

- Measured values:** Displays power on ph. L1, L2, L3, and power sum L1+L2+L3, all showing 0,00 kW. It also shows FB power and FB energy, both at 0,00 kW and 0,00 kWh.
- Connect/Disconnect/Configure connection...:** Buttons for system control. The status is 'Disconnected'.
- Error and info status:** Shows 'Voltage L1 missing', 'Low tariff (night tariff)', and 'Summer time' as active. Other status info includes 'Output test is active' and 'CombiWATT is active'.
- Configuration/object name:** A text field for naming the configuration.
- Time to activate CombiWATT:** 6908 s. **Date (controller):** 19. 12. 2014. **Sunrise today:** 7:55. **Time (controller):** 8:31:27. **Firmware version:** 1.0. **Date (client):** 9. 2. 2015. **Serial number:** 45000002. **Time (client):** 11:32:46.
- Output status:** A table showing the status of SSR 1 (BOILER) and SSR 2-4, and Relay 1-2. SSR 1 is 'enforced' with a schedule from 15:00 to 19:00 and a limit of 8,60 kWh. SSR 2-4 and Relays 1-2 are 'not used'.
- Bottom bar:** Contains icons for 'Open', 'Save', 'Reset to defaults...', 'Read', 'Write', and 'Exit'.

EXAMPLE NO. 2 – ALL 6 LOADS, CONTROL MODE - SUM OF ALL PHASES

The same boiler as specified in example No. 1, swimming pool filtering pump and 6 kW instantaneous water heating for the swimming pool (pump and three-phase heating element). Recommended peak power output of the PV-plant is more than 8 kWp.

Boiler heating process has 1st priority (SSR No. 1). Requirements are the same as in example No. 1.

Filtering pump has 2nd priority (relay No. 1), nominal motor rating 0.3 kW (value in VA is usually not specified here), and it must run exactly for 6 hours per day and the minimum switching time is 5 minutes. The daily amount of required power for this motor is 1.8 kWh. If there is not sufficient amount of sunshine available, the system will use the low tariff. The motor should not be running at night between 23:00 and 5:00 - not to disturb during night (this also depends on the local low tariff time schedule so that the motor can get a chance to run).

Pump for heating has 3rd priority (relay No. 2), power output 0.16 kW and it must run always if the heating element of the pool heating is on. The typical off delay time for the pump is 1 minute. We only want to turn the swimming pool heating when there is surplus energy available. Make sure swimming pool heating is fitted with a thermal protection! Heating elements are connected to the remaining outputs with lower priorities (rest of SSR outputs).

We recommend using separate contactors for motors, but due to their low power consumption rate it is not really necessary. WATTrouter ECO device uses low tariff signal and the boiler and swimming pool filtration motors operate under CombiWATT mode.

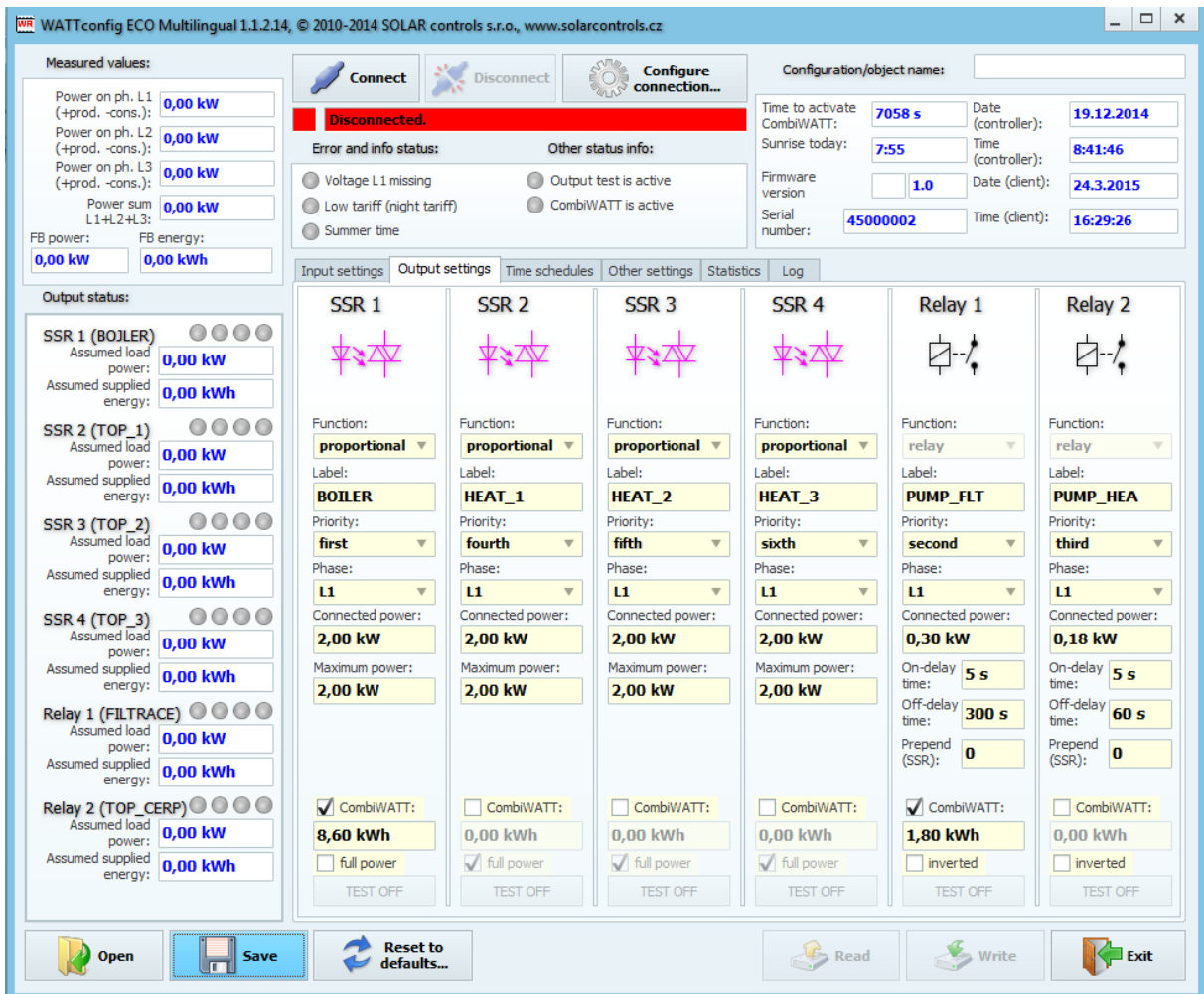

Time schedule for boiler is set the same as in example No. 1.

Two time schedules are assigned for pool filtering pump. The first of them describes restriction of the output during "daytime" between 8:00 and 23:00. This restriction ensures the motor runs approximately 6 hours and therefore, it applies only if the daily energy counter exceeds 1.8 kWh. The second time schedule restricts operation of the motor between 23:00 and 5:00 without any special requirements or conditions. The necessary prerequisite for correct application of these two time schedules is correct configuration of daily energy counter reset. As reset mode there must be selected "at sunrise" or "at fixed time". The fixed time for second case should be selected in the morning before 8:00.

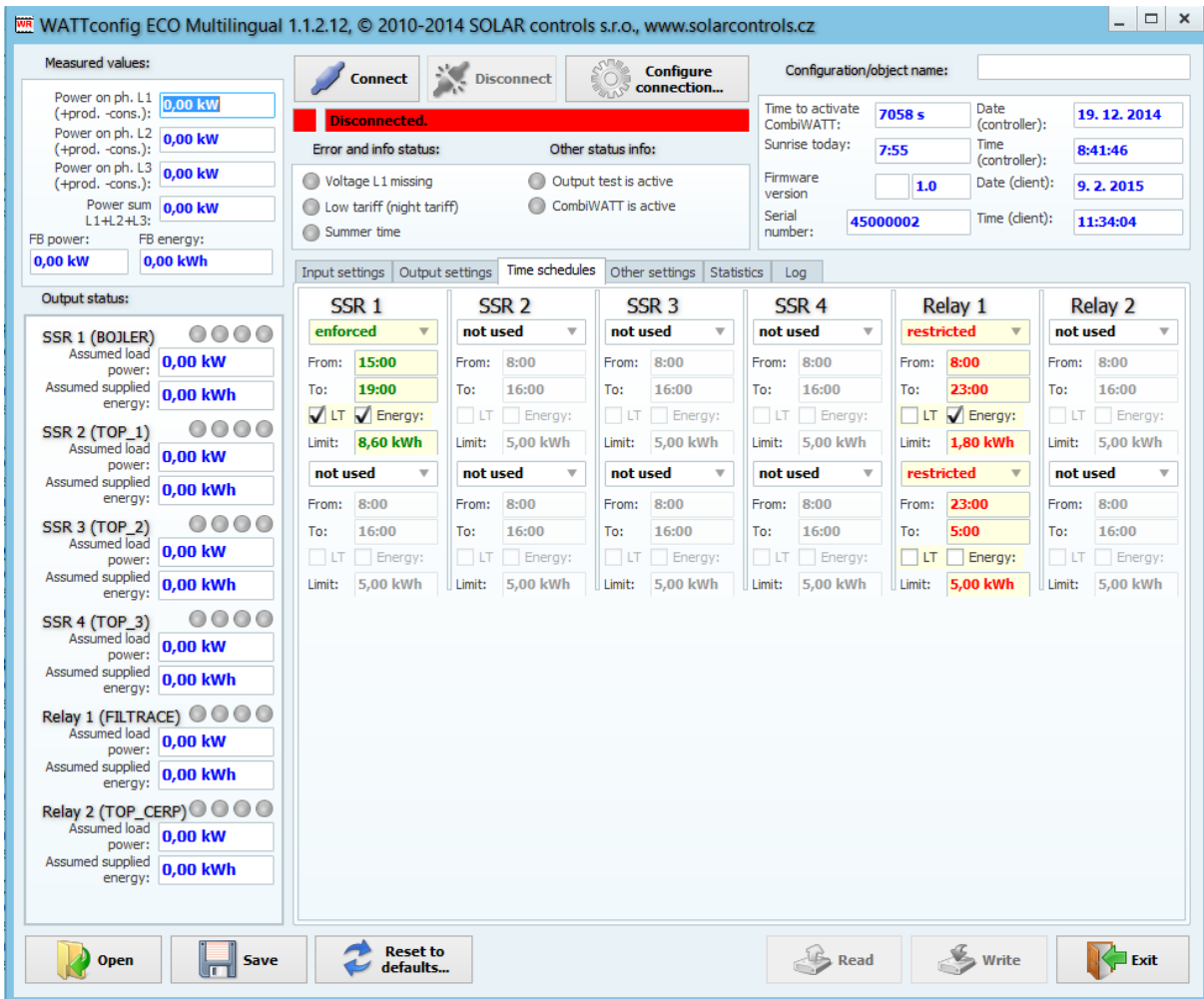

The screenshot shows the WATTrouter ECO Multilingual 1.1.2.12 software interface. The main window is titled "WATTrouter ECO Multilingual 1.1.2.12, © 2010-2014 SOLAR controls s.r.o., www.solarcontrols.cz".

Measured values:

- Power on ph. L1 (+prod., -cons.): 0,00 kW
- Power on ph. L2 (+prod., -cons.): 0,00 kW
- Power on ph. L3 (+prod., -cons.): 0,00 kW
- Power sum L1+L2+L3: 0,00 kW
- FB power: 0,00 kW
- FB energy: 0,00 kWh

Configuration/object name: [Empty field]

Time to activate CombiWATT: 7058 s

Date (controller): 19. 12. 2014

Sunrise today: 7:55

Time (controller): 8:41:46

Firmware version: 1.0

Date (client): 9. 2. 2015

Serial number: 45000002

Time (client): 11:34:04

Output status:

- SSR 1 (BOILER): Assumed load power: 0,00 kW; Assumed supplied energy: 0,00 kWh
- SSR 2 (TOP_1): Assumed load power: 0,00 kW; Assumed supplied energy: 0,00 kWh
- SSR 3 (TOP_2): Assumed load power: 0,00 kW; Assumed supplied energy: 0,00 kWh
- SSR 4 (TOP_3): Assumed load power: 0,00 kW; Assumed supplied energy: 0,00 kWh
- Relay 1 (FILTRACE): Assumed load power: 0,00 kW; Assumed supplied energy: 0,00 kWh
- Relay 2 (TOP_CERP): Assumed load power: 0,00 kW; Assumed supplied energy: 0,00 kWh

Time Schedules:

Device	Mode	From	To	LT	Energy	Limit
SSR 1	enforced	15:00	19:00	<input checked="" type="checkbox"/>	<input checked="" type="checkbox"/>	8,60 kWh
SSR 2	not used	8:00	16:00	<input type="checkbox"/>	<input type="checkbox"/>	5,00 kWh
SSR 3	not used	8:00	16:00	<input type="checkbox"/>	<input type="checkbox"/>	5,00 kWh
SSR 4	not used	8:00	16:00	<input type="checkbox"/>	<input type="checkbox"/>	5,00 kWh
Relay 1	restricted	8:00	23:00	<input type="checkbox"/>	<input checked="" type="checkbox"/>	1,80 kWh
Relay 2	not used	8:00	16:00	<input type="checkbox"/>	<input type="checkbox"/>	5,00 kWh
Relay 1	restricted	23:00	5:00	<input type="checkbox"/>	<input type="checkbox"/>	5,00 kWh
Relay 2	not used	8:00	16:00	<input type="checkbox"/>	<input type="checkbox"/>	5,00 kWh

Buttons: Open, Save, Reset to defaults..., Read, Write, Exit

EXAMPLE NO. 3 – ALL 6 LOADS, CONTROL MODE - EACH PHASE INDEPENDENTLY

Loads specified in example No. 2 but more complex connection. Control mode is set for each phase independently.

Connect the following to L1 phase:

- boiler has 1st priority (SSR 1 No. 1), requirements are the same as in example No. 1.
- pool filtering pump has 2nd priority (relay No. 1), requirements are the same as in example No. 2.

Connect the following to L2 phase:

- pump for heating has 1st priority (relay No. 2), requirements are the same as in example No. 2.
- one heating coil with 2nd priority (SSR 2).

Connect the following to L3 phase:

- auxiliary contact with 1st priority (SSR 3 operating as a relay), will also turn on the circulation pump connected actually to phase L2 (here, a small amount of power may be drawn from the public grid at phase L2, but in order to prevent it we would have to use two circulation pumps).
- 2nd heating coil with 2nd priority (SSR 4).

Unfortunately, in this "one-regulator" configuration setup, the 3rd heating coil cannot be connected. We would have to make sure that the circulation heat pump will be turned on by one output only - using a time schedule, or completely separately - outside of WATTrouter.

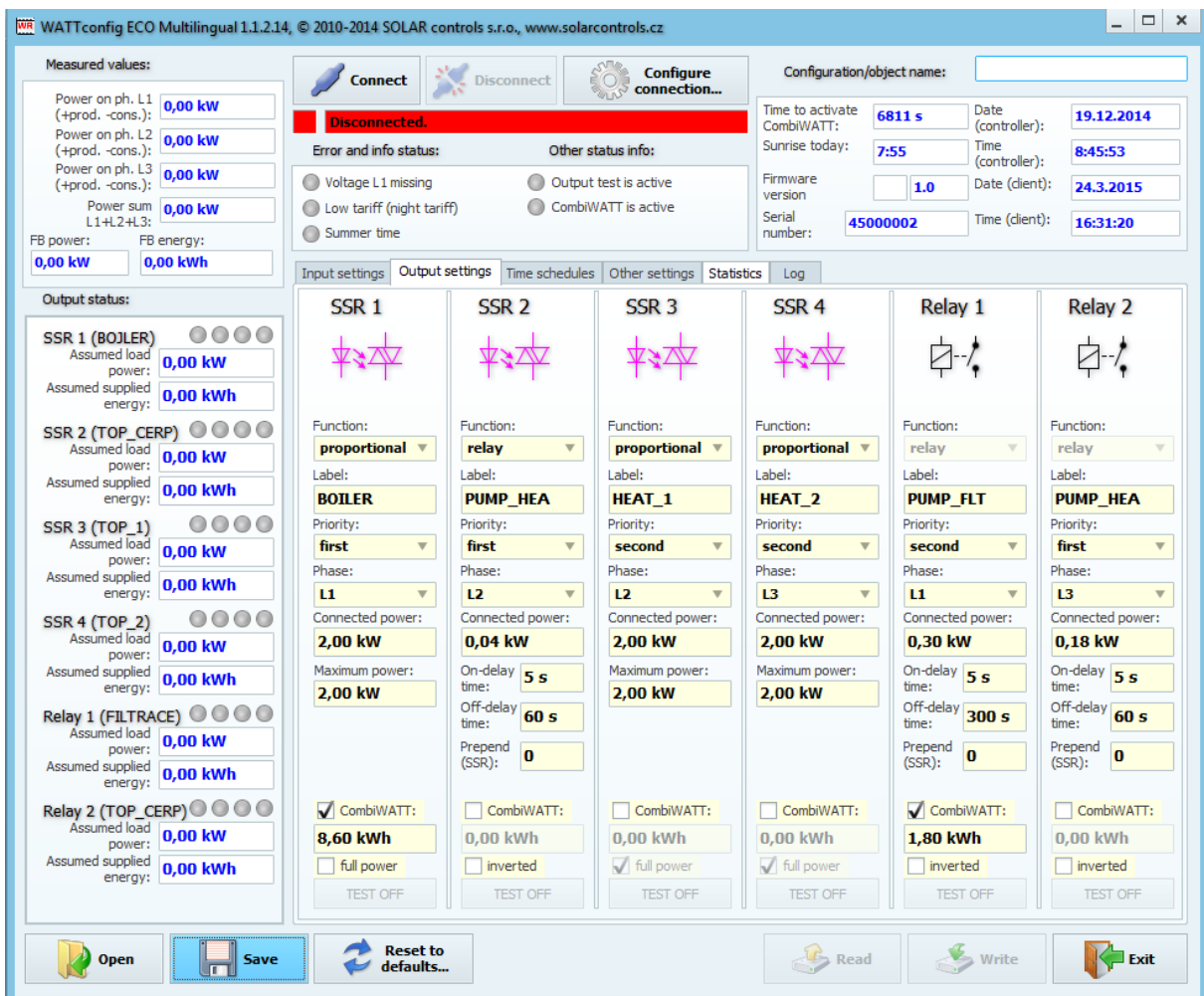

The screenshot shows the WATTrouter ECO configuration interface. On the left, 'Measured values' show 0,00 kW for all phases. The 'Output status' section lists SSR 1 (BOILER), SSR 2 (TOP_CERP), SSR 3 (TOP_1), and SSR 4 (TOP_2) with their respective assumed load and supplied energy. The main configuration area shows settings for SSR 1 through SSR 4 and Relay 1 through Relay 2. SSR 1 is set to 'proportional' mode with a 'first' priority on L1 phase. SSR 2 is set to 'relay' mode with a 'first' priority on L2 phase. SSR 3 is set to 'proportional' mode with a 'second' priority on L2 phase. SSR 4 is set to 'proportional' mode with a 'second' priority on L3 phase. Relay 1 is set to 'relay' mode with a 'second' priority on L1 phase. Relay 2 is set to 'relay' mode with a 'first' priority on L3 phase. The interface also includes tabs for 'Input settings', 'Time schedules', 'Other settings', 'Statistics', and 'Log', along with buttons for 'Connect', 'Disconnect', and 'Configure connection...'. The status bar at the bottom shows 'Disconnected'.

Time schedules are the same as in example No. 2.

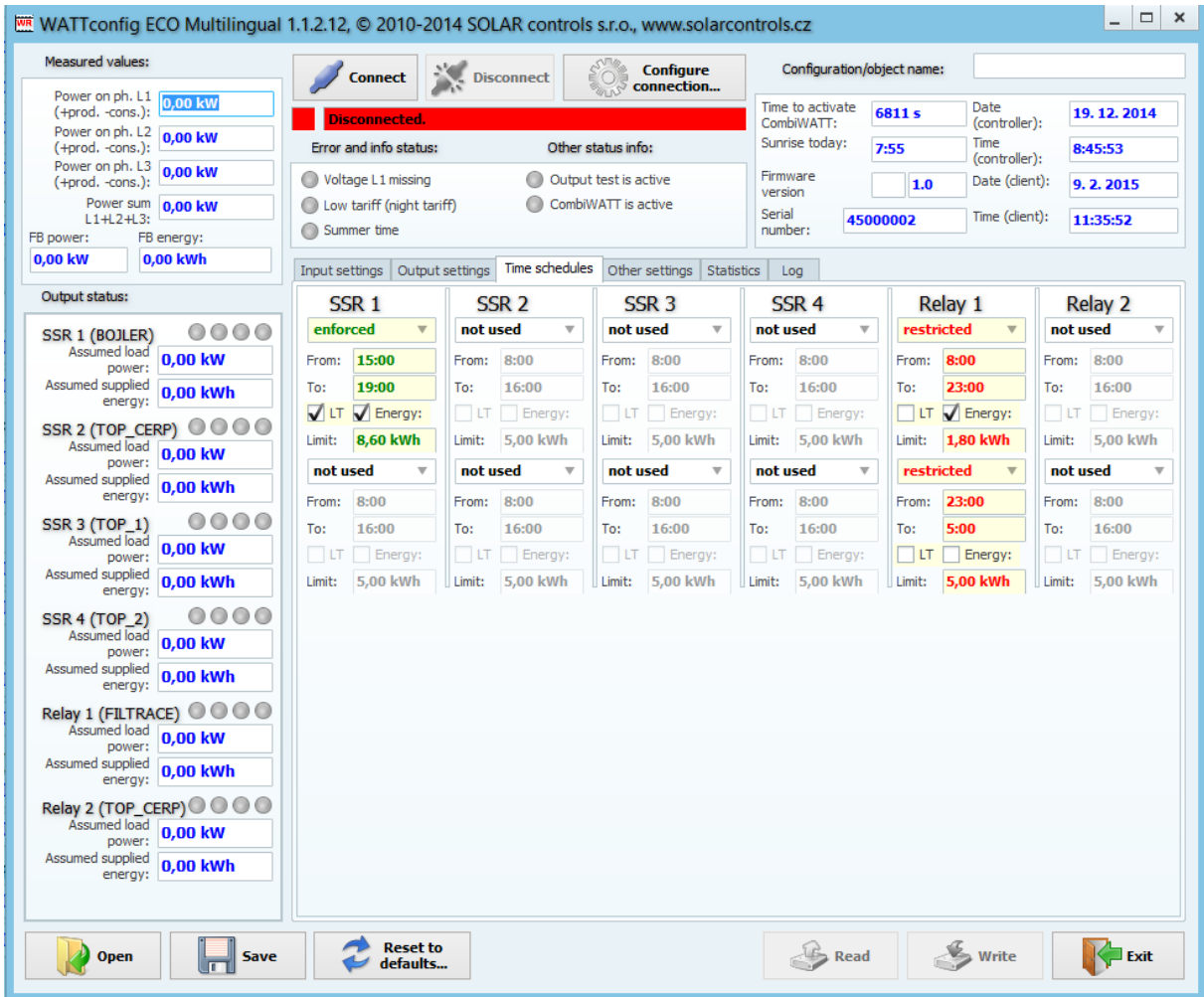

The screenshot shows the 'WATTrouter ECO Multilingual 1.1.2.12' software interface. The main window is titled 'Configuration/object name:'. The status bar at the top indicates 'Disconnected'. The interface is divided into several sections:

- Measured values:** Shows power on ph. L1, L2, L3, and Power sum L1+L2+L3, all at 0,00 kW. FB power and FB energy are also 0,00 kW.
- Connect/Disconnect/Configure connection...** buttons are visible.
- Error and info status:** Shows 'Disconnected' in a red bar. Other status info includes 'Voltage L1 missing', 'Low tariff (night tariff)', 'Summer time', 'Output test is active', and 'CombiWATT is active'.
- Time to activate:** 6811 s. Date (controller): 19. 12. 2014. Sunrise today: 7:55. Time (controller): 8:45:53. Firmware version: 1.0. Date (client): 9. 2. 2015. Serial number: 45000002. Time (client): 11:35:52.
- Output status:** Lists SSR 1 (BOJLER), SSR 2 (TOP_CERP), SSR 3 (TOP_1), SSR 4 (TOP_2), Relay 1 (FILTRACE), and Relay 2 (TOP_CERP) with their assumed load and supplied energy.
- Time Schedules:** A table showing schedules for SSR 1 through SSR 4 and Relay 1 through Relay 2. SSR 1 is 'enforced' with a limit of 8,60 kWh. SSR 2, 3, and 4 are 'not used'. Relay 1 is 'restricted' with a limit of 1,80 kWh.
- Bottom Bar:** Contains buttons for 'Open', 'Save', 'Reset to defaults...', 'Read', 'Write', and 'Exit'.

Device	Status	From	To	Limit	LT	Energy
SSR 1	enforced	15:00	19:00	8,60 kWh	<input checked="" type="checkbox"/>	<input checked="" type="checkbox"/>
SSR 2	not used	8:00	16:00	5,00 kWh	<input type="checkbox"/>	<input type="checkbox"/>
SSR 3	not used	8:00	16:00	5,00 kWh	<input type="checkbox"/>	<input type="checkbox"/>
SSR 4	not used	8:00	16:00	5,00 kWh	<input type="checkbox"/>	<input type="checkbox"/>
Relay 1	restricted	8:00	23:00	1,80 kWh	<input type="checkbox"/>	<input checked="" type="checkbox"/>
Relay 2	not used	8:00	16:00	5,00 kWh	<input type="checkbox"/>	<input type="checkbox"/>

EXAMPLE NO. 4 – 5 LOADS, CONTROL MODE - EACH PHASE INDEPENDENTLY

Boiler and pool filtering system specified in example No. 2 plus 2 resistive electric heaters and a heat pump used to heat the swimming pool. Everything in more complex connection plus control mode set for each phase separately.

Each electric heater draws 2 kW and should be supplied only with the surplus energy, independently of the household primary heating system. These heaters must be deactivated at summer time - either through built in thermostats, by deactivating fuse switches for respective outputs or by deactivating them in the software.

The heat pump draws power of 1.3 kW and it is supplied only with the surplus energy, or manually, outside of the WATTrouter device.

Connect the following to L1 phase:

- boiler has 1st priority (SSR 1 No. 1), requirements are the same as in example No. 1.
- pool filtering pump has 2nd priority (relay No. 1), requirements are the same as in example No. 2.

Connect the following to L2 phase:

- 1st electric heater with 1st priority (SSR 2).
- heat pump with 2nd priority (relay No. 2).

Connect the following to L3 phase:

- 2nd electric heater with 1st priority (SSR 3).

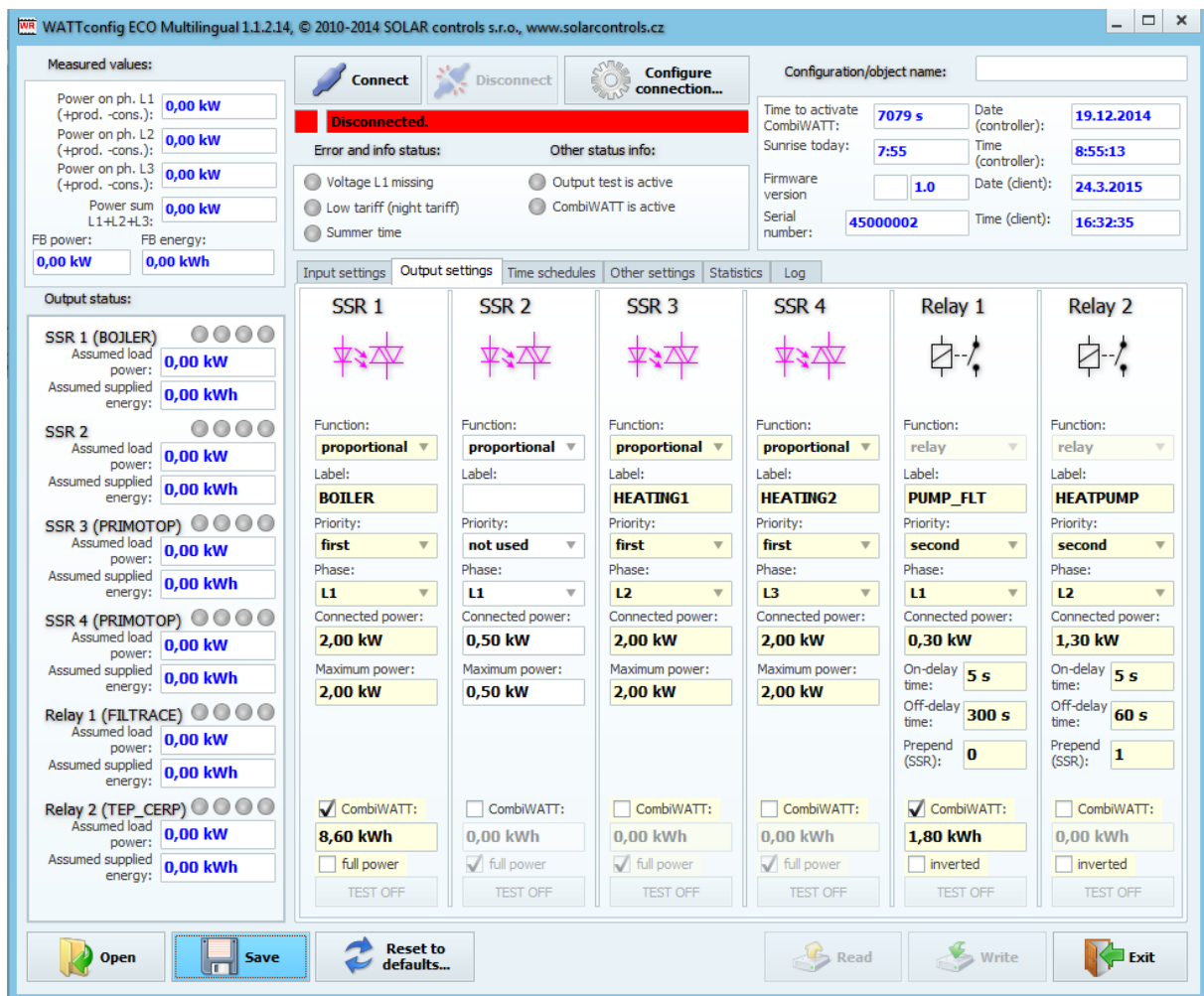

The screenshot shows the WATTrouter configuration software interface. At the top, it displays 'Measured values' for power on phases L1, L2, and L3, all at 0.00 kW. The 'Output status' section shows four SSRs and two relays. SSR 1 (BOILER) is set to 'proportional' function, 'first' priority, and 'L1' phase, with a connected power of 2.00 kW. SSR 2 (HEATING1) is set to 'proportional' function, 'not used' priority, and 'L1' phase, with a connected power of 0.50 kW. SSR 3 (HEATING2) is set to 'proportional' function, 'first' priority, and 'L2' phase, with a connected power of 2.00 kW. SSR 4 (HEATING2) is set to 'proportional' function, 'first' priority, and 'L3' phase, with a connected power of 2.00 kW. Relay 1 (PUMP_FLT) is set to 'relay' function, 'second' priority, and 'L1' phase, with a connected power of 0.30 kW. Relay 2 (HEATPUMP) is set to 'relay' function, 'second' priority, and 'L2' phase, with a connected power of 1.30 kW. The interface also includes tabs for 'Input settings', 'Output settings', 'Time schedules', 'Other settings', 'Statistics', and 'Log'. At the bottom, there are buttons for 'Open', 'Save', 'Reset to defaults...', 'Read', 'Write', and 'Exit'.

Time schedules are the same as in example No. 2.

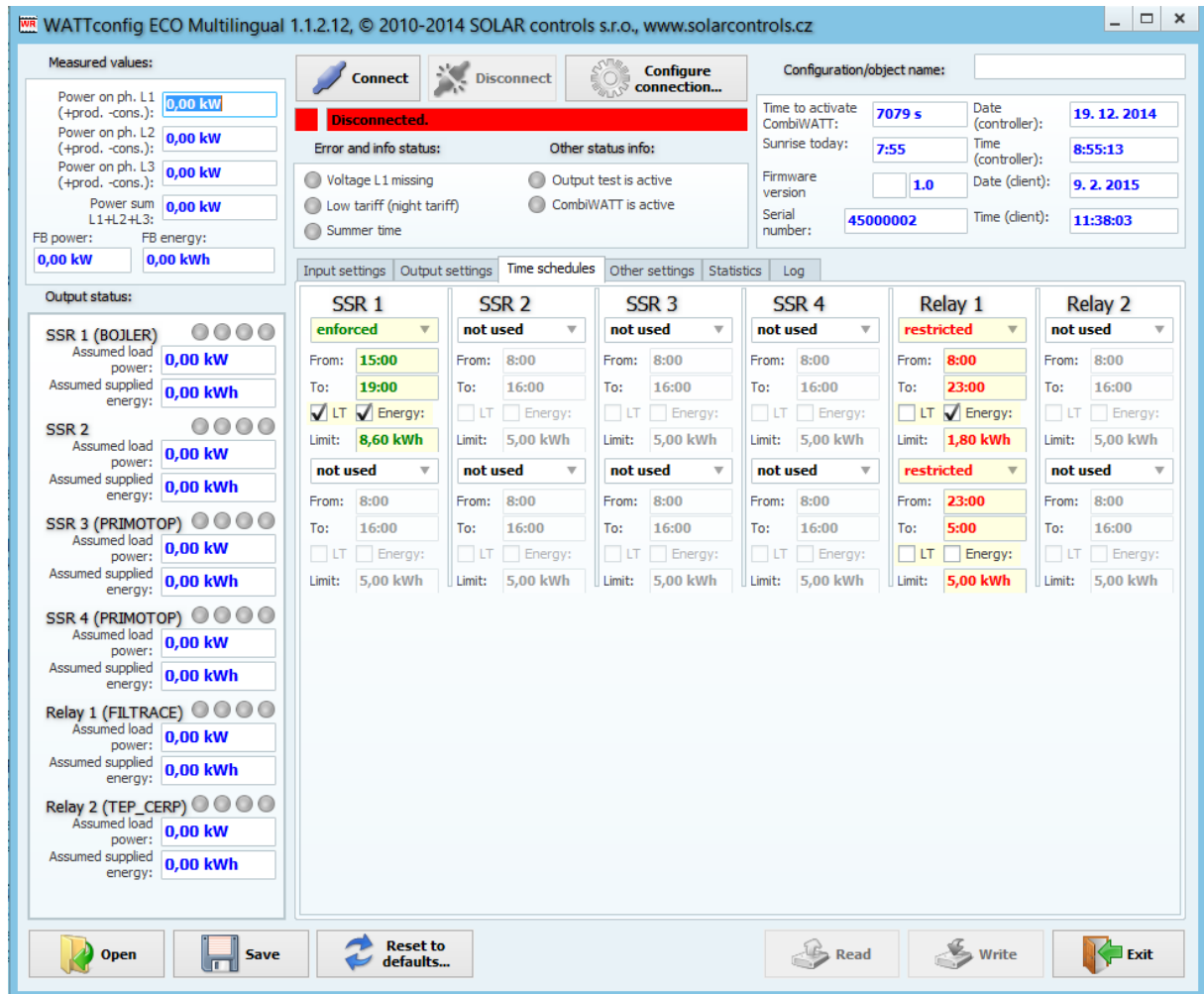

WATTrouter ECO Multilingual 1.1.2.12, © 2010-2014 SOLAR controls s.r.o., www.solarcontrols.cz

Measured values:

- Power on ph. L1 (+prod., -cons.): **0,00 kW**
- Power on ph. L2 (+prod., -cons.): **0,00 kW**
- Power on ph. L3 (+prod., -cons.): **0,00 kW**
- Power sum L1+L2+L3: **0,00 kW**
- FB power: **0,00 kW**
- FB energy: **0,00 kWh**

Output status:

- SSR 1 (BOJLER):** Assumed load power: **0,00 kW**; Assumed supplied energy: **0,00 kWh**
- SSR 2:** Assumed load power: **0,00 kW**; Assumed supplied energy: **0,00 kWh**
- SSR 3 (PRIMOTOP):** Assumed load power: **0,00 kW**; Assumed supplied energy: **0,00 kWh**
- SSR 4 (PRIMOTOP):** Assumed load power: **0,00 kW**; Assumed supplied energy: **0,00 kWh**
- Relay 1 (FILTRACE):** Assumed load power: **0,00 kW**; Assumed supplied energy: **0,00 kWh**
- Relay 2 (TEP_CERP):** Assumed load power: **0,00 kW**; Assumed supplied energy: **0,00 kWh**

Configuration/object name: _____

Time to activate CombiWATT: **7079 s** **Date (controller):** **19. 12. 2014**

Sunrise today: **7:55** **Time (controller):** **8:55:13**

Firmware version: **1.0** **Date (client):** **9. 2. 2015**

Serial number: **45000002** **Time (client):** **11:38:03**

Error and info status: **Disconnected.**

Other status info:

- Voltage L1 missing
- Output test is active
- Low tariff (night tariff)
- CombiWATT is active
- Summer time

Time Schedules:

Device	Mode	From	To	Limit	LT	Energy
SSR 1	enforced	15:00	19:00	8,60 kWh	<input checked="" type="checkbox"/>	<input checked="" type="checkbox"/>
SSR 2	not used	8:00	16:00	5,00 kWh	<input type="checkbox"/>	<input type="checkbox"/>
SSR 3	not used	8:00	16:00	5,00 kWh	<input type="checkbox"/>	<input type="checkbox"/>
SSR 4	not used	8:00	16:00	5,00 kWh	<input type="checkbox"/>	<input type="checkbox"/>
Relay 1	restricted	8:00	23:00	1,80 kWh	<input type="checkbox"/>	<input checked="" type="checkbox"/>
Relay 2	not used	8:00	16:00	5,00 kWh	<input type="checkbox"/>	<input type="checkbox"/>
Relay 1 (bottom)	restricted	23:00	5:00	5,00 kWh	<input type="checkbox"/>	<input type="checkbox"/>
Relay 2 (bottom)	not used	8:00	16:00	5,00 kWh	<input type="checkbox"/>	<input type="checkbox"/>

Buttons: Open, Save, Reset to defaults..., Read, Write, Exit

TROUBLESHOOTING

The following table shows the most frequent problems and usual solutions:

Problem description	Possible causes	Solution
The regulator has been fitted according to the manual but after you switch on the circuit breaker no LED lights up or flashes.	The circuit breaker is on but the supply voltage is missing.	Check or measure whether there is any voltage between terminals L1 and N.
	Regulator failure/defect	Replace the regulator or take it to repair.
The regulator has been fitted according to the manual but after you turn on the circuit breaker the green LED quickly flashes, the regulator does not work and the WATTconfig ECO software shows all zeros.	The regulator runs in the boot mode without any application firmware	Use the WATTconfig software and load the newest firmware version or load the version you prefer
The regulator does not communicate with computer	The regulator has no voltage	Check whether green LED PWR is on and the regulator is powered.
	Computer is not properly connected with the regulator	Check the USB cable connection, try using different network cable, or try the cable with different device (printer for example).
	Computer cannot detect connected regulator.	Check USB cable connection. When USB device is being registered in your PC, the yellow LED COM must flash temporarily.
	USB interface driver was not correctly installed in your computer	Make sure the USB interface driver is correctly installed and Windows device manager detects it as a USB serial converter and USB serial port.
	USB interface driver is not configured properly	Use the USB interface driver configuration window in WATTconfig ECO and reset all parameters back to default values and choose correct port.
	The Log window records communication errors	A very few communication errors is considered a common status and it depends on the actual load put on Microsoft Windows OS or on the operating system running in the regulator or disturbance on communication line. However, if there are many errors inspect the functionality of your PC, or it may also be a conflict at the USB interface in your PC.
	Regulator failure/defect	Replace the regulator or take it to repair.
Measured powers are not displayed or they are displayed incorrectly	The current sensing module is not connected	Connect the current sensing module according to this manual.
	Incorrect phase sequence	Make sure that phase connected to terminal L1 is the same as phase measured at input I_L1. Also inspect the validity of

		phase sequence settings (see Phase order settings field in the main window).
	Incorrect current orientation settings	Set the current orientations in WATTconfig software as specified in this manual.
	Regulator or current sensing module defect	Replace the regulator and/or current sensing module or take them to repair.
There are suspicious waveforms shown in chart "Current wave oscilloscope"	This is normal	During normal operation there may be shown even "exotic" waveforms. Be sure this is the real current flowing through the phase wire, a superposition of currents flowing through the connected appliances which are not sinusoidal or their power factor varies from one.
Positive measured power value (production) differs too much from the value on the inverter display	There is connected some load, which decreases this value.	No defect
	Inverter shows approximate values, or the status is not stable	No defect
	Incorrect phase sequence or incorrect current orientation settings	Follow the steps specified in the previous item.
Low tariff signal is missing	Low tariff signal is not connected	Connect the low tariff signal to LT terminal. You must connect the signal through an auxiliary relay as specified in this manual.
	Low tariff signal is not active	Wait until the signal is active, or manually test the auxiliary relay by switching it on (some relays offer this option).
	Regulator failure/defect	Replace the regulator or take it to repair.
FB input does not work	Output with open collector is connected in reverse polarity	Observe polarity of the device output (energy meter, inverter).
	Signal coming from the output is an unsupported impulse signal	Use only device with impulse output whose signal carries information about the measured energy and has a minimum impulse width of 1 ms. Signal parameters are described in chapter Technical specifications.
	Regulator failure/defect	Replace the regulator or take it to repair.
The TEST button cannot be used to switch on some of the connected loads	The relevant load is not connected or it is connected incorrectly	Check the connection of the relevant load and switch on the corresponding circuit breaker or fuse switch.
	The load is connected correctly but cannot be switched on	Check whether the load is fitted for example with a thermal protection system or a thermostat, which is currently off.
	Wireless peripheral device is off or out of the range.	Check functions of wireless peripheral device. In case of problems with coverage

		of signal, use the signal repeater. Consult this problem with technical support.
	Output LED is defect or there is another regulator defect	Replace the regulator or take it to repair.
Outputs do not switch on as they should	Output is not activated	Activate the output by setting the relevant priority.
	PV-plant does not provide sufficient power output	Check whether there is enough surplus energy available in respective phase wire or sum of phases L1 + L2 + L3 is positive, depending on configured control mode.
	Incorrectly set priorities or connected power values	Check the priority setting of your loads and connected power settings according to their power ratings.
	Incorrectly set items in Expert setting	Check the settings in the Power offset field. Also check the CombiWATT production limit field, which should be low.
You cannot load firmware, even if you try repeatedly	Incorrect or corrupted *.scf file	Load only original regulator firmware for the WATTrouter ECO device.
	Communication errors	Make sure that there are no problems with the connection of the regulator to PC, or in the PC alone (viruses etc.).
	Regulator failure/defect	Replace the regulator or take it to repair.
Flashing red LED	The system detected error status	Follow instructions in the LED statuses chapter.
When the available surplus energy is decreased, the SSR output with higher priority is switched off earlier than the relay output with lower priority	This is normal	Relay outputs have always longer delay when in the process of disconnecting. In order to make sure that energy from the power grid is not drawn unnecessarily all connected SSRs with higher priority may be disconnected earlier than the relay outputs with lower priority.
CombiWATT software runs even if PV-plant produces power	This is normal	CombiWATT will be initiated even if during the time specified in the CombiWATT delay time field, no production is detected at any phase wire, which may occur if the PV-plant produces small amount of energy or if loads with large power consumption operate for long time and consume all available surplus energy. If you want to eliminate this behavior, increase the value in the CombiWATT delay time field.
Solid state relay (SSR) does not switch on	SSR is not connected correctly	Check for proper terminal connection and observe polarity of SSR anodes.
	Incompatible relay	Always use a SSR with zero cross switch and minimum DC control voltage of 4VDC.
	Regulator failure/defect	Replace the regulator or take it to repair.

Data in statistics don't correspond with reality	This is normal	The data are indicative only; the device does not have accurate data from utility/billing meters. Furthermore, the device may be configured improperly, i.e. does not evaluate the same as your utility meter does.
Statistics suddenly erased	This is normal	There was a date change in the regulator or power failure during writing the history into EEPROM after midnight.
SC-Gateway module is inserted in regulator, but all Link LEDs are off	Incorrect inserting of module	Remove and insert module once again based on installation module manual.
	Regulator or module failure/defect	Replace the module or regulator
Wireless peripheral can't be registered, even after longer period while connected. Window Add wireless station is not displayed.	Station out of signal range	Test the wireless peripheral so it is placed temporary closer to the regulator. Once this time it is detected, there is necessary to extend signal range with signal repeater. Consult this problem with technical support.
	Station is incompatible	It is different type of wireless peripheral, which is not compatible with SC-Gateway module.
	Stations is defective	Follow the installation manual for the wireless peripheral.
	SC-Gateway module does not react	Reset the regulator and wait about 1 minute. Then repeat the network registration procedure.
	SC-Gateway module failure/defective	Replace the module
Wireless station does not switch or switches incorrectly	Station out of signal range	Test the wireless peripheral so it is placed temporary closer to the regulator. Once this time it is detected, there is necessary to extend signal range with signal repeater. Consult this problem with technical support.
	Stations is defective	Follow the station manual
	SC-Gateway module does not react	Reset the regulator and wait about 1 minute. Then test the function of the peripheral.

MAINTENANCE AND REPAIRS

The regulator and current sensing module have been designed as maintenance-free units, provided that they were configured and fitted according to instructions specified in this manual. We recommend inspecting the operation of the entire system at regular intervals (at least once in a month, for example, when inspecting the status of the PV-plant). Focus mainly on the load switching process and heat dissipation of power SSRs.

Should you discover a defect which cannot be repaired according to instructions specified in the Troubleshooting chapter, contact your distributor (applies both to warranty and post warranty repairs).

Defect on current sensing module is very improbable. In case of a defective regulator, you can send only the regulator for repair or replacement. The current sensing module may still remain fitted without the regulator. Even if electric currents flow through measuring coils, the module will not be damaged.

Never attempt to repair your device by yourself! If you do so, you are putting yourself at risk of electric shock. Further, your entire warranty will be void!

TECHNICAL SPECIFICATIONS

Parameter	Value, notes
Main parameters	
Supply voltage	230 V~, 50 Hz
Power consumption – stand-by mode	<3 VA
Power consumption – 1 relay output	0.4 W
Power consumption – all outputs switched on and loaded with maximum allowable currents	4 W (this value does not include the switching losses of power SSRs)
Current measuring range	0-20 A~ (±5 %), 50 Hz (±5 %)
Voltage range	230V~ (±5%), 50Hz (±5%)
Maximum steady currents allowed to flow through current sensing module	0-40 A~ (±5 %), 50 Hz (±5 %)
Active power measuring accuracy	5% ± 0,05kW
Output and input parameters	
L1 input	230 V~, 50 Hz
I_L1, I_L2, I_L3 inputs:	Secondary currents from measuring coils. Maximum allowed voltage against GND terminal is 5.5 V.
Relay outputs	230 V~, 50 Hz, max. 10 A, 2300 W (it is recommended to connect load with $\cos(\Phi) \neq 1$ via external contactor) Protection: Regular circuit breaker, type B
External outputs for connection of solid state relays SSR (S+, S1-, S2-,S3-,S4-)	0 or 5 VDC, isolated from power grid supply SSR parameters: control DC min. 4VDC, SSR must switch at zero (zero switch). Protection: based on instructions specified in the SSR relay manual
External outputs - connection with PWM function SSR (S+, S1-, S2-,S3-,S4-)	0 or 5 VDC, isolated from power grid supply PWM parameters: carrier frequency 200 Hz, duty cycle 0-100% in 1% steps. Protection: based on instructions specified in the manual of connected device
LT, FB inputs	0 or 5 VDC, isolated from power grid supply May be switched using regular relay outputs or optocouplers with open collector, always against GND. Minimum pulse width and gaps for FB inputs is 1ms.
USB Connection	USB 1.1/ USB 2.0, isolated both from power grid supply and additionally optically isolated
Dynamic characteristics	
Active power measuring period (effective values)	typically 600 ms (including averaging of switched-on SSRs)
Regulation dynamics (full scale) at SSR output	typically 3 s (from 0 to 100 % of power output and vice versa)
Relay output on-delay time	Programmable (minimum of 2s)

Relay output off-delay time	Programmable (minimum of 2s)
Other parameters	
Maximum diameter of wires connected to terminals	2.5 mm
Maximum diameter of wires passing through measuring transformers	9 mm (including insulation)
Distance of the current sensing module and the regulator	<2 m (longer wires are acceptable, but they reduce the accuracy approx. by 0.2% per 2m).
Distance of the regulator and solid state relay	<10 m
Working position	any
Mounting	Regulator: DIN 35mm or wall mounted using 2 screws with round or sink head and with diameter of up to 6mm. Current sensing module: DIN 35mm or wall mounted using 1 screw with round or sink head and with diameter of up to 6mm.
Overvoltage category	III
Electric strength	4 kV / 1 min (power supply (L1, N)-output, output - output, power supply-current input, external output, etc.(GND,I_L...,LT,FB...,S+,S1- ,S2- ,S3- , S4-))
Pollution degree	2
Operational temperature range	-20°C to +40°C
Storage temperature range	-40 °C to +80 °C
Protection (power supply)	B6A
IP code	Regulator and current sensing module: IP 20
Dimensions (WxHxD)	Regulator: 70x110x64mm (4 modules) Current sensing module: 70x110x64mm (4 modules)
Weight	Regulator: 350g current sensing module: 100g
Noise level (including SSR)	Only passive cooling, for power SSR is necessary to ensure sufficient heat dissipation.
Battery for real-time backup	CR2032 lithium, usual lifetime> 6 years
Warranty period	24 months

RECYCLING

After the product life is over the product may be disassembled, recycled or disposed of at a save dumpsite.

Legal regulations regarding electronic waste treatment have to be observed in respective country.

Do not dispose in regular household waste!

DECLARATION OF CONFORMITY



Company:

SOLAR controls s.r.o. (manufacturer name)
Brojova 25, Plzeň, 32600, Czech Republic(manufacturer address)
29109795 (manufacturer id)

Hereby declares that this product:

WATTrouter ECO (product name)
WRE 01/06/14 (regulator) and WT 02/10 (current sensing modules) (type/model)
Designed for to optimize self-consumption of electric power produced by photovoltaic power plant (function)

To which this declaration relates is in conformity with the following directives, standards and other normative documents, provided that it is installed, maintained and used in application for which it was made, in accordance with relevant installation standards and manufacturer's instructions:

Directives:

- LVD Directive 2006/95 EC
- EMC Directive 2004/108 EC

Standards:

- EN 61010-1:2010
- EN 61000-3-2:2006+A1:08+A2:09
- EN 61000-3-3:2008
- EN 61000-3-11:2000
- EN 61000-4-2:2009
- EN 61000-4-4:2012
- EN 61000-4-5:2006
- EN 61000-4-11:2004
- EN 61000-6-3:2007

Year of affixing the CE marking: 2014

Declaration issued:

Plzeň, October 1, 2014

(place and date)

Ing. Tomáš Krýsl, Company Executive

(name, job title and signature of responsible person of the manufacturer)

 **solar** S.R.O. **CONTROLS**
ELEKTRONICKÉ A DIAGNOSTICKÉ SYSTÉMY
Brojova 2053/25, PLZEŇ, CZ 326 00
IČ: 29109795 DIČ: CZ29109795
Tel: +420 724 543 601 www.solarcontrols.cz