

E-Port Home Double Installation guide



Contents

1.	Introduction	3
1.1	Brief description	3
1.2	About the Guide	3
1.3	Warnings	4
1.4	Safety	4
2.	Technical description	5
2.1	Basic system information	5
2.2	Constituent components	6
2.3	Technical data	7
3.	Important assembly instructions	
3.1	Usage conditions	8
3.2	Preparation ahead of assembly	8
3.3	Aids and required tools	8
3.4	Assembly descriptions	8
4.	Feet placement planning	9
5.	Installation of transverse beams	10
5.1	Fixing the supports	10
5.2	Fixing the supports to the feet	11
6.	Installation of the superstructure	12
6.1	Fixing the squares	12
6.2	Fixing the cross beams to the squares	12
6.3	Fixing the transverse lamellae	12
7.	Fixing the trapezoidal sheet	13
7.1	Fixing the shield flashings	14
8.	Fixing the roof gutter	16
8.1	Downpipe	17
9.	Planning the module area for a transverse installation	18 19
10.	Fixing the profile rails for a transverse installation	19
11.	Transverse installation of modules	21
11.1	Fixing the Clickstones	21
11.2	Fixing the modules from the outside	23
11.3	Fixing the modules from the inside	25
11.4	Fixing further rows	25

Congratulations on the purchase of the E-Port Home. It will provide you with numerous advantages – a covered spot for your vehicle, more independence from your electricity support, and – last but not least – a stylish and innovative design piece at your doorstep.

In order for you to be fully satisfied with your product, we encourage you to get better acquainted with all the details included in the present guide.

1. Introduction

1.1 Brief description

E-Port Home Double is a sturdy double parking spot, allowing for an installation of up to 15 solar modules on its roof. The delivered items include the base frame of steel profiles and all other minor installation components to install the modules on the trapezoidal sheet roof. The delivery also includes roof shield plates and a drainage system.

1.2 About the Guide

Instructions

These instructions describe the installation of the E-Port Home system and fixing the PV modules on the roof. The guide also contains system-specific information on the planning of the work, safety indications and a list of the components to be installed.

Please read both this installation manual and the above mentioned documents carefully prior to any installation, maintenance or disassembly work. You will be provided with all information for safe and complete installation, maintenance and disassembly. However, if you have any questions after having read these documents, please contact Mounting Systems GmbH.

User group

These installation instructions are intended for the following persons (user group):

- Skilled personnel
- Instructed personnel

Skilled personnell

Skilled personnel are persons who, on the basis of their professional training, are able to execute installation, maintenance and disassembly work properly.

Instructed personnel

Instructed personnel are persons who have been instructed and taught appropriately regarding the assigned tasks and the possible risks in the event of improper conduct. An instructed person must have received instructions regarding the required safety devices, precautions, relevant regulations, accident prevention regulations as well as operating conditions and must have demonstrated their competence. The implemented work must be inspected and accepted by skilled personnel.

Guidance notes

The following guidance notes enhance the orientation when handling this installation manual:

Pictograms:



This symbol indicates important information and useful tips.



This Symbol indicates ways and means to make the installation process easier

1.3 Warnings

The following warnings are used in these Installation Instructions to indicate safety-related information. They include:

- Warning symbols (pictograms)
- Signal words that identify the hazard level
- Information about the type and source of the hazard
- Information about the potential consequences if the hazard is disregarded
- Measures for the prevention of hazards and the prevention of injuries or damage to property

The signal words of the warnings respectively indicate one of the following hazard levels:

 DANGER	Indicates a potentially mortal danger, disregard for which may result in death or serious injury.
 WARNING	Indicates a potentially dangerous situation that may result in serious injury or damage to property.
 CAUTION	Indicates a potentially dangerous situation that may result in injuries or damage to property if ignored.
 ATTENTION	Indicates potential danger that can result in damage to the property.

1.4 Safety

All universally valid safety instructions for products of Mounting Systems GmbH are listed in the document "Installation manual for PV mounting systems – general part". Please read this document carefully and observe the instructions given therein: Do not use the product in a manner other than intended, comply with the obligations of the owner and observe all general and specific safety instructions.

In addition, please observe the specific safety instructions given in this installation manual for all installation work. The specific safety instructions are positioned in each case directly with the respective installation step.

2. Technical description

2.1 Basic system information

Below you will find the most important components of the system:

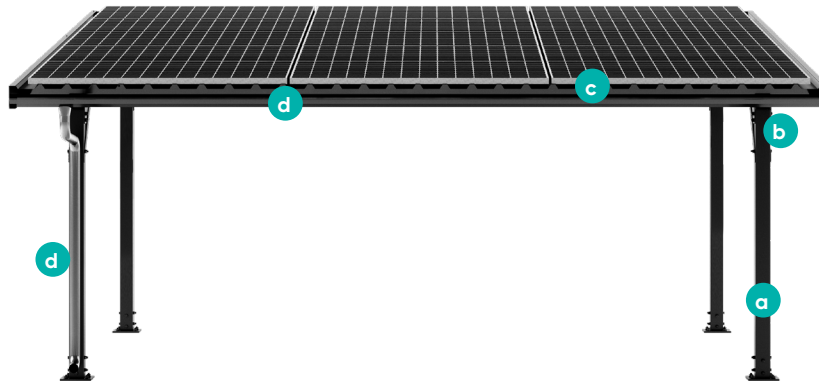

Picture 2.1-1 E-Port Home Double

Components of the E-Port Home Double:

- a Support
- b Square
- c Trapezoidal sheet
- d Roof gutter

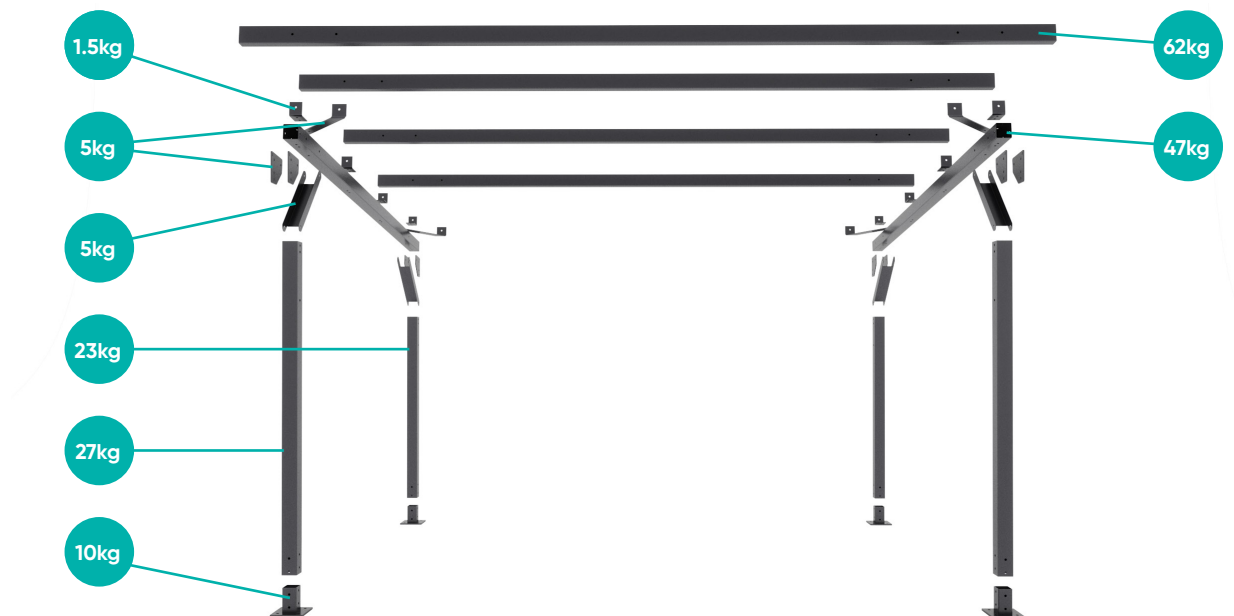

Picture 2.1-2 Component weight

2.2 Constituent components

Check the delivery for completeness. Components of the vertical pipe in the drainage system (17-39) and the module installation kit (40) are not shown.



Foot = 4x



Rear support (2572mm) = 2x



Front support (2132mm) = 2x



Transverse beam = 2x



Sheet piece = 4x



Sheet piece = 4x



Cross brace = 2x



Cross brace = 2x



Square = 8x



Transverse beam = 4x

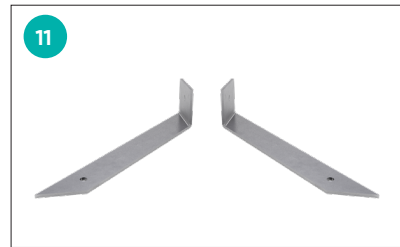

Diagonal bracket left = 2x, right = 2x

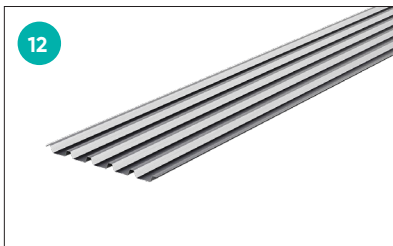

Trapezoidal steel sheet = 6x



Edge flashing short (400mm) = 6x

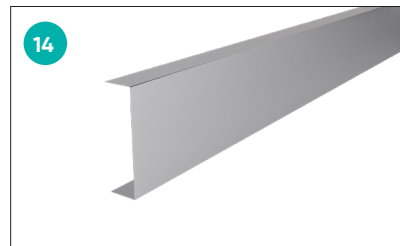

Edge flashing long (1950mm) = 9x

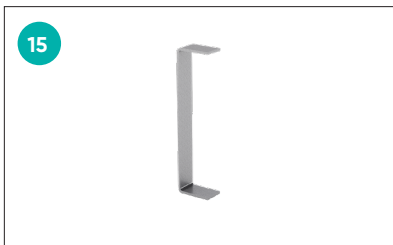

Flashing holder = 5x



Calotte = 116x

CAUTION

Unpacking and assembly require the participation of many people. The sheet metal components may bend out of shape.

13 **14**

Part no.	Count	Designation	Part no.	Count	Designation
1	4	Foot	20	2	Downpipe bend
2	2	Rear support 120x120x3-2572mm	21	1	Downpipe 3 m
3	2	Front support 120x120x3-2132mm	22	1	Gutter bottom, left
4	2	Transverse beam 120x120x3-4365mm	23	1	Gutter bottom, right
5	4	Sheet piece	24	1	Gutter connector
6	4	Sheet piece	25	1	Drainage support 120/90
7	2	Long support	26	2	Downpipe clamp
8	2	Short support	27	1	Downpipe outlet
9	8	Square	28	16	ISO 4017 - M16 x 160 (Bolt)
10	4	Transverse beam 140x80x4-6335mm	29	144	DIN 125 - A17 (Washer)
11	2	Diagonal bracket left	30	72	ISO 4032 - M16 (Hexagon nut)
11	2	Diagonal bracket right	31	16	ISO 4017 - M16x 140 (Bolt)
12	6	Trapezoidal steel sheet	32	12	ISO 4017 - M16x 110 (Bolt)
13	6	Edge flashing short	33	85	M5,5x 0,8 x 19 (Sheet metal screw)
14	9	Edge flashing long	34	116	M5,5x 0,8 x 50 (Sheet metal screw)
15	5	Flashing holder	35	16	Anchor bolt FAZ II 20 160
16	116	Calotte – length 35/50mm	36	4	Cap
17	1	Roof gutter 120mm; 3m	37	144	Screw cap – synthetic material M16
18	1	Roof gutter 120mm; 3,3 m	38	16	Screw cap – synthetic material M20
19	8	Gutter hook	39	28	ISO 4014 – M16x150
			40	1	Module installation kit 720-1748 (frame height 33-45mm)

2.3 Technical data

Set includes:	<ul style="list-style-type: none"> • support structure for photovoltaic modules • trapezoidal sheet for the entire structure (ca. 1,1m x 6,0m)
Foundation:	<p>Anchored in the ground</p> <p>Easy installation not requiring special tools</p>
Modules:	<p>Place for up to 15 modules (1.0m x 1.7m)</p> <ul style="list-style-type: none"> • for a module capacity of 300 Wp • total power 4,5 kWp
Options:	<ul style="list-style-type: none"> • Roof side shielding • Drainage
Colour	Black, matt (RAL 9005)
Condition:	No shadow

3. Important assembly instructions

3.1 Usage conditions

- maximum snow loadt: 0,69kN/m²
- maximum wind loadt: 0,68kN/m²
- no shadow
- free, unobstructed assembly area
- suitable ground



DANGER

Excess load could damage the roof!

For your own safety, during installation and assembly and in order to secure the trapezoidal sheet, use wooden planks or the like for safe footing.



DANGER

Risk of death due to falling components

Components falling from the roof may cause severe injury or death!

- Components falling from the roof may cause severe injury or death!
- Before installation and assembly make sure that the used materials conform to the local static requirements!

3.2 Preparation ahead of assembly

Mounting Systems recommends you should acquire complete knowledge about the local conditions before ordering your E-Port Home Double. Pay particular attention to:

- the preparation of foundations
- the minimum number of people required for safe assembly: 6

3.3 Aids and required tools

You will need the following tools to install the framework structure:

- hammer drill with a 20 mm concrete bit
- 5 mm Allen key
- hammer
- frame ladder
- battery powered screwdriver
- TX30, SW8 bits for the screwdriver
- size 24 wrench
- SW24 open-end wrench
- chalk line
- level
- 7 m measuring tape
- torque wrench

3.4 Assembly descriptions

The following chapters describe all planning and installations for the E-Port Home in the correct order. Chapters 4-8 describe the installation of the frame roof system itself, and chapters 9, 10 and 11 describe the layout of modules.

Please adhere to the indicated installation stages and adhere to the safety instructions provided.

4. Feet placement planning

Measure the placement of the feet (1) and fix them in the measured positions. For this purpose, use the anchors installed in the prepared foundation.



Make sure that the feet are aligned (1) properly so that the supports (2) and (3) can be installed in them as needed.

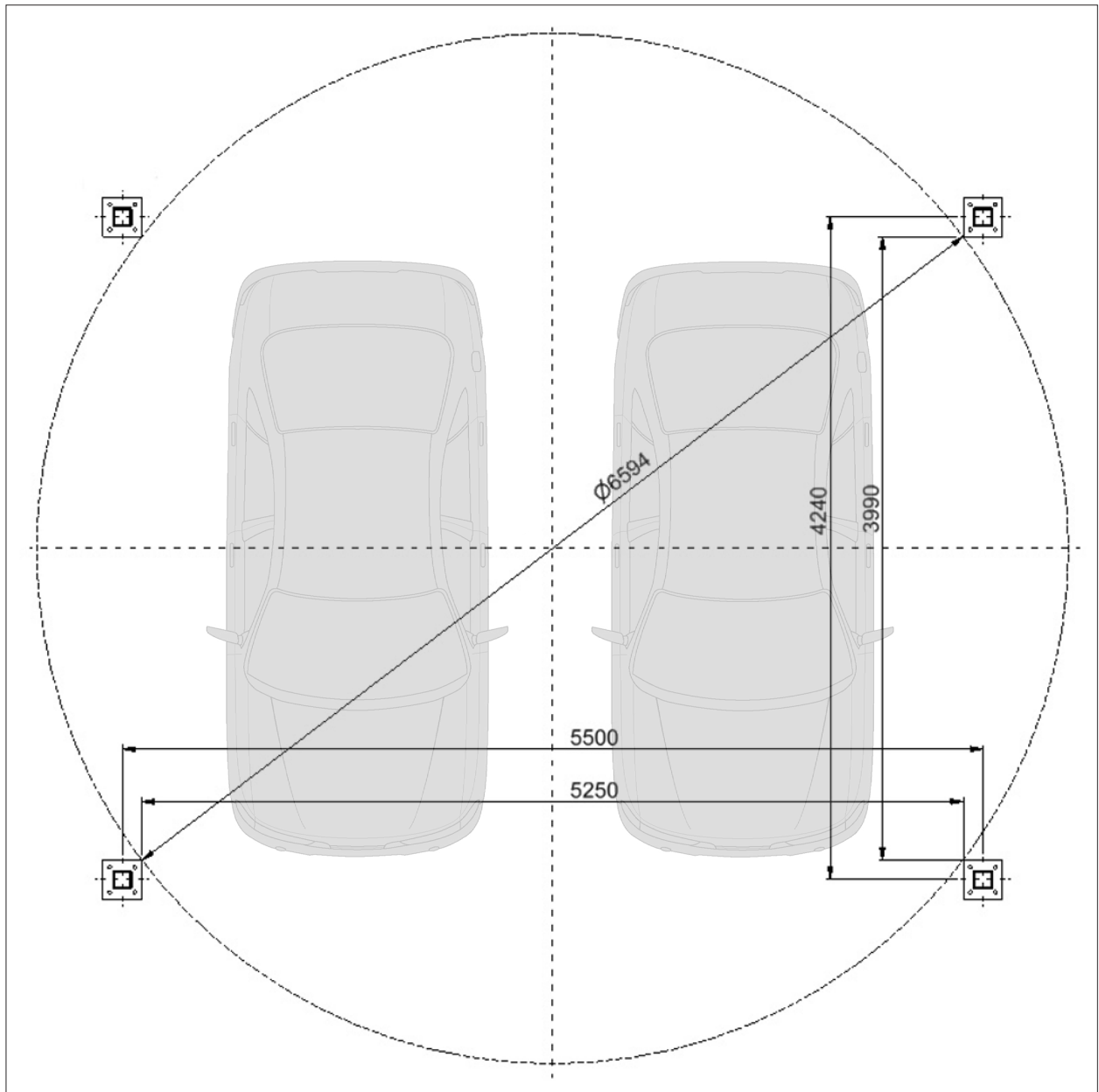

Picture 4.-1

Installation steps:

Fix the four feet in the concrete foundation; each foot is installed using four bolts (35).

Tightening torques:

- Bolt anchorr M20 – 200Nm

5. Installation of transverse beams

The supports (2) and (3) and transverse beams (4) must be laid out as needed beside both feet (1).

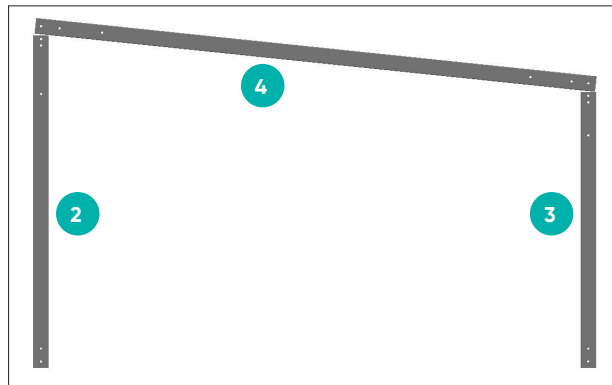

Picture 5.-1

5.1 Fixing the supports

Installation steps:

- Fix the support (2) to the beam (4) using two sheet pieces (5), four M16x160 bolts, eight A17 washers and four M16 nuts.
- Fix the support (3) to the beam (4) by two sheet pieces (6), four M16x160 bolts, four A17 washers and two M16 nuts.
- The transverse beam (7) between the support (2) and beam (4) is fixed by two M16x150 bolts, four A17 washers and two M16 nuts.
- The transverse beam (8) between the support (3) and beam (4) is fixed by two M16x150 bolts, four A17 washers and two M16 nuts, just like in the step above.

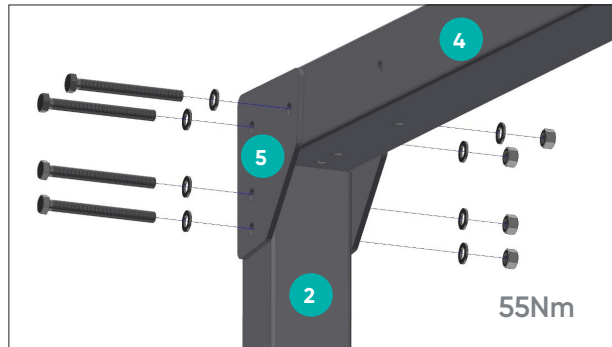

Picture 5.1-1

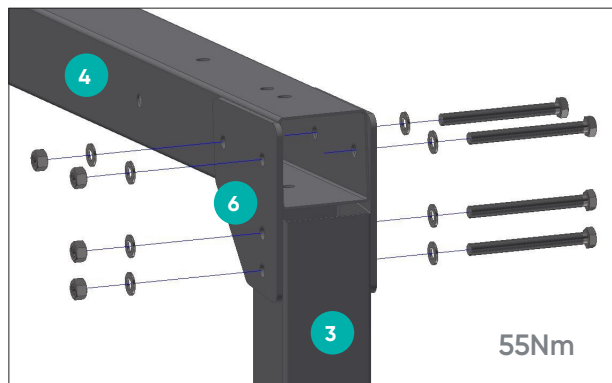

Picture 5.1-2

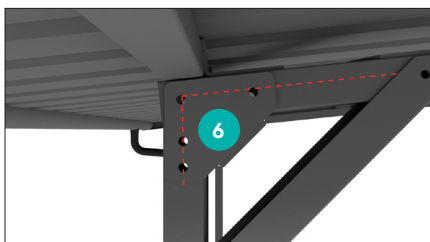

Picture 5.1-1.1

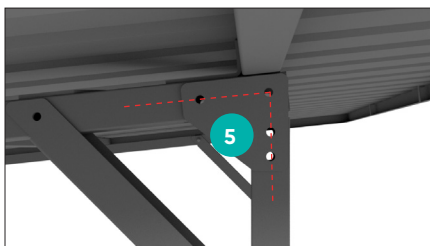

Picture 5.1-1.2

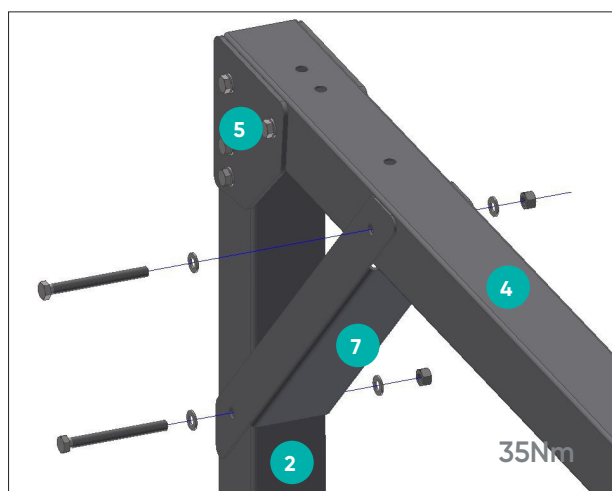

Picture 5.1-3

5.2 Fixing the supports to the feet

Installation steps:

- The screwed construction is to be placed in the feet (1).
- Then fix the supports to the feet (1) using four M16x140 bolts, eight washers and four nuts.
- Repeat item 5 and fix the other side component in the other two feet (1).

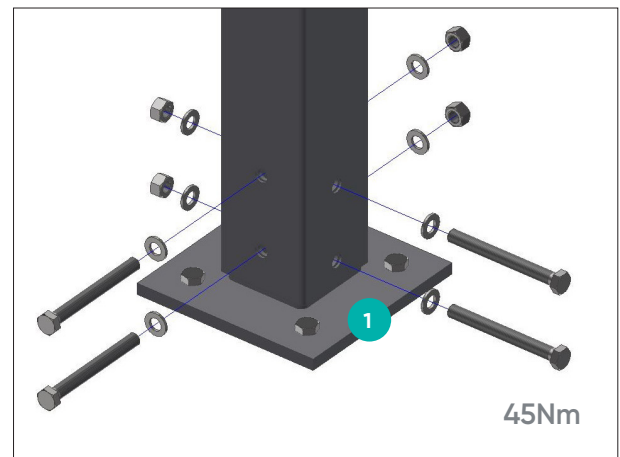

Picture 5.2-1



DANGER

Risk of death due to falling components

Components falling from the roof may cause severe injury or death!

- Components that fall when the structure is erected may cause grave injury and component damage!

6. Installation of the superstructure

6.1 Fixing the squares

Each square (9) is fixed to the beam (4) at the designated spot using two M16x150 bolts, four washers and two nuts

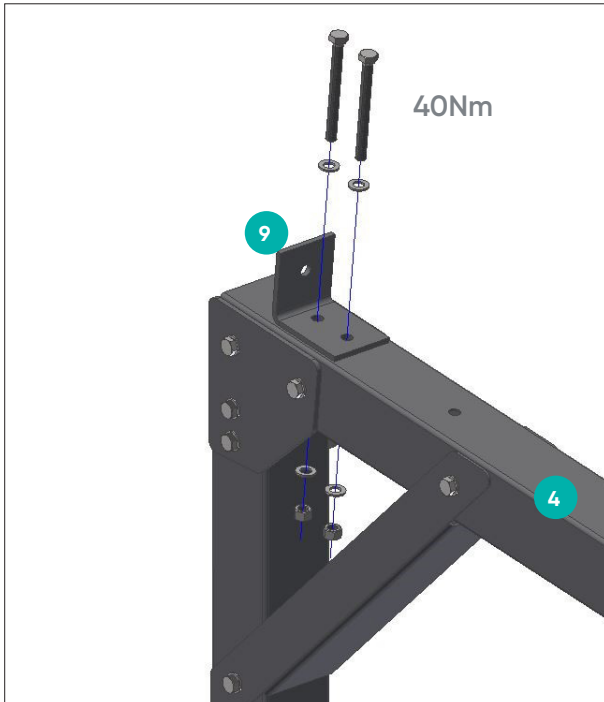

Picture 6.1-1

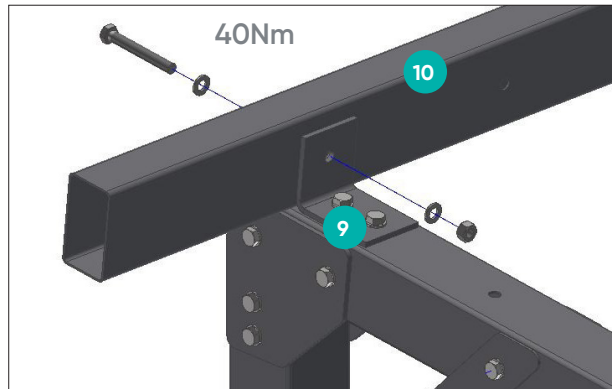

Picture 6.2-1

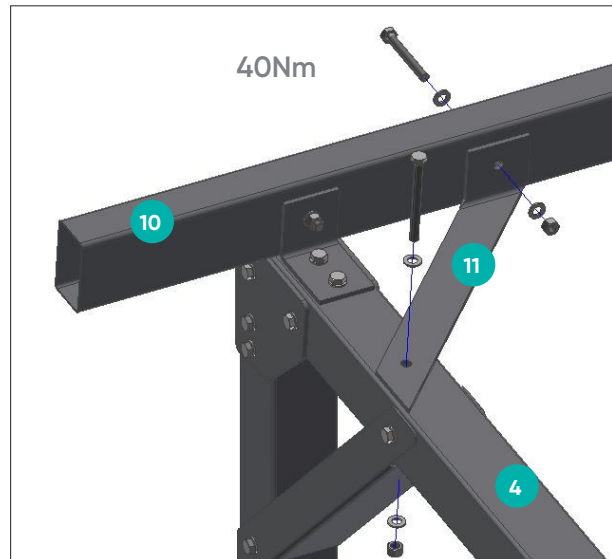

Picture 6.3-1

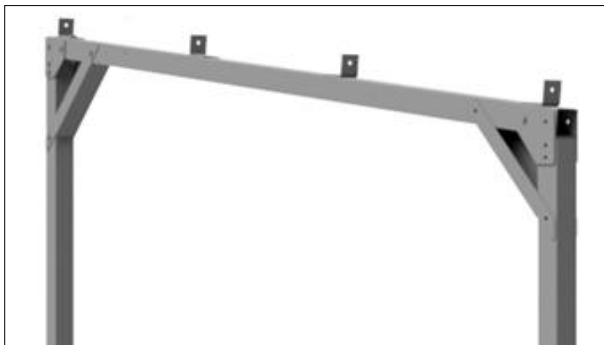

Picture 6.1-2

6.1-2 Position of bracket (9) see picture

6.2 Fixing the cross beams to the squares

The cross beams (10) are fixed to the ready squares (7) using one M16x110 bolt, two washers and one nut per square (9).

6.3 Fixing the transverse lamellae

Installation steps:

- Fix the transverse lamellae (11 each on left and right side) to the outer cross beams (10)
- Fixing of the beam (4) requires a M16x150 bolt, two washers and a M16 nut.
- Fixing of the cross beam (10) requires a M16x110 bolt, two washers and a M16 nut.
- Next place the plates in the support openings and cover the nuts with caps.



DANGER

Warning note: Protect the transverse beam suitably from falling.



ATTENTION

Please pay attention to the prevailing wind direction, when laying the trapezoidal sheet.

Please make sure to remove all metal filings after drilling the holes to avoid corrosion

7. Fixing the trapezoidal sheet

The trapezoidal sheet (12) is fixed to the cross beams (10) at the crests, using M5x0.8x50 sheet metal screws and calottes (16).

Drilling screw M5 - Screw-in speed max. 1800 U/min

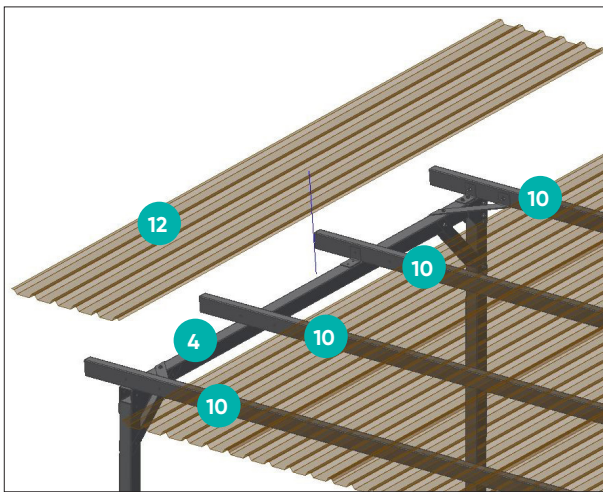

Picture 7-1

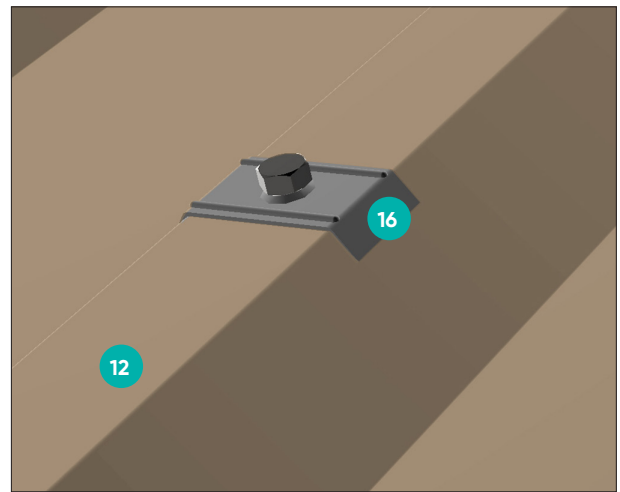

Picture 7-2

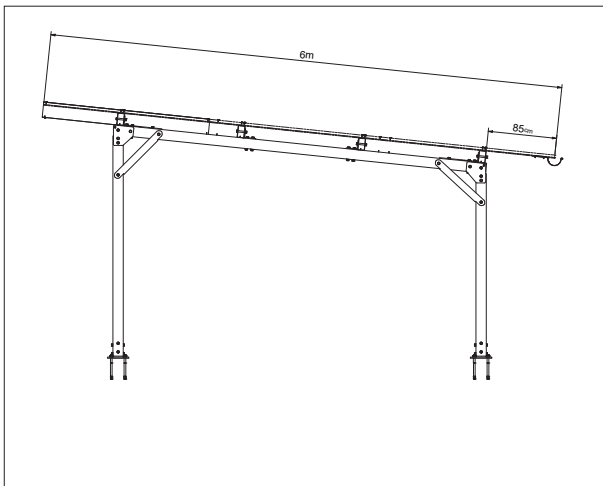

Picture 7-3

7.1 Fixing the shield flashings



Picture 7.1-1

Installation steps:

Fixation of the flashings on the sides

- Fastening the flashings (14) with the the M5x0.8x20 self-tapping screws on the cross members (10) from above and from below.
- Please adjust the flashings to make sure that the entire length of the E-Port is covered.
- Please use the short flashings for the overlaps (13).



Picture 7.1-2

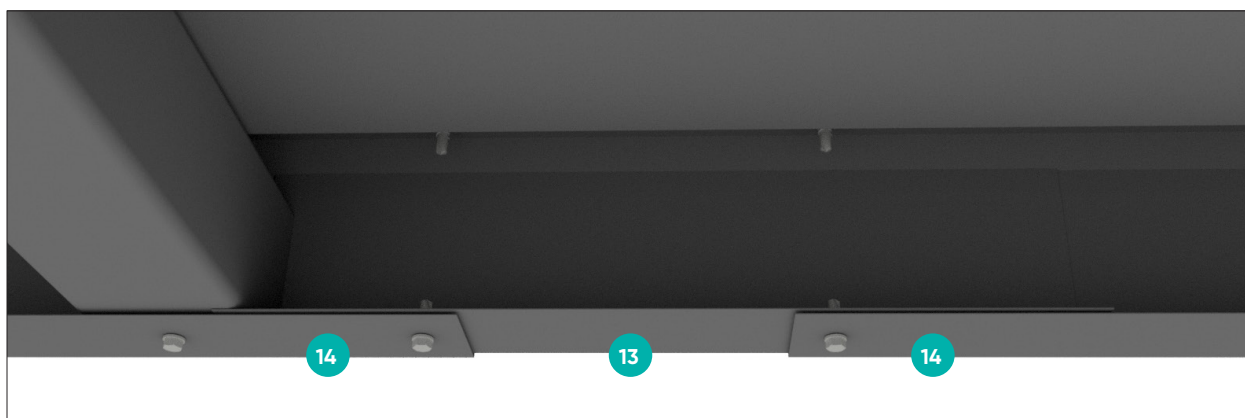

Picture 7.1-3

Installation steps:

Fixation of the flashings at the front and backside

- Fasten the flashing (14) with the flashing holder (15) to the trapezoidal sheet (12), using a self-tapping screw from above and below through the flashing.

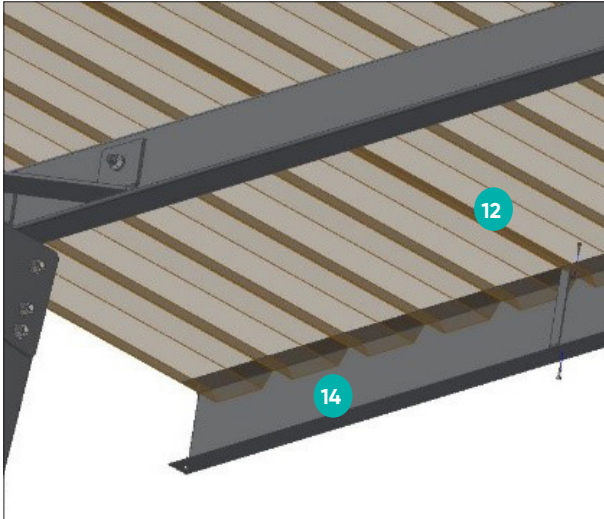

Picture 7.1-4

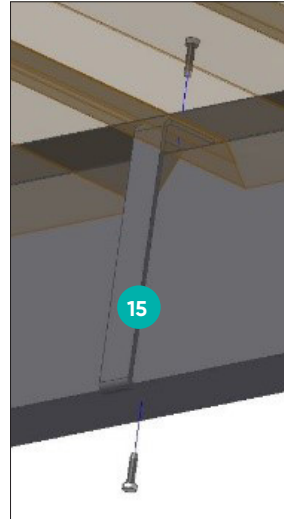

Picture 7.1-5

Please use two self-tapping screws each to fix the overlap at the corner from above and from below.

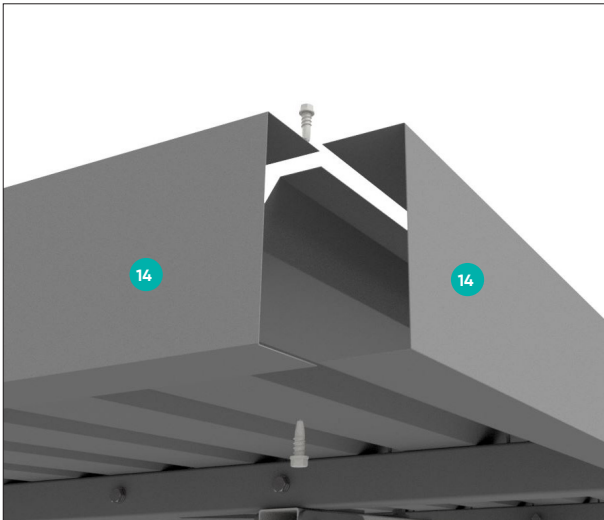

Picture 7.1-6

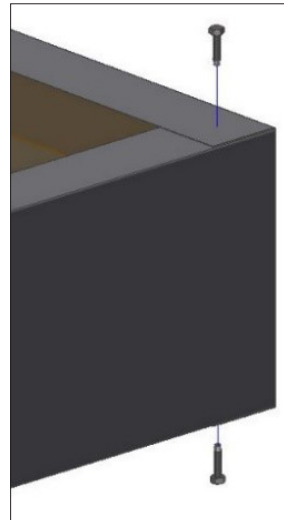

Picture 7.1-7

8. Fixing the roof gutter

Installation steps:

- In the roof gutter (17) cut out an opening where the downpipe is to be fixed (21)
- Install the roof gutter to the sheet metal crests using the roof hooks/ clamps and sheet metal screws.
- Pick even distances between the roof hooks.



Picture 8.-1

Fixing the hooks to the gutter:

- Space six hooks along the entire roof length (distance between hooks - ca. 84 cm).
- The roof hooks are attached to the trapezoidal sheet from below and with the help of two screws / rivets per hook from above, please make sure that there is a fall of 2% in the direction of the downpipe.

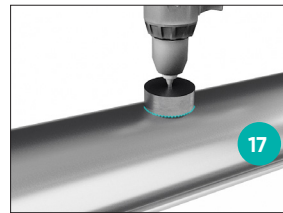

Picture 8.-2

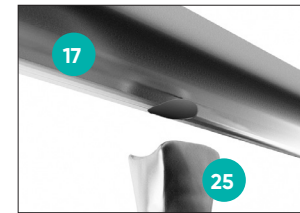

Picture 8.-3

Installation of the gutter connectors:

- Both gutter components must be slid together, then insulate the opening above and below the connection.
- Correct the installation by extending the middle piece above the rear end of the roof gutter and then above the front edge of the gutter.
- Manually compress the middle piece so that it touches with the roof gutter.
- Then bend the latches to so that the clamps close.

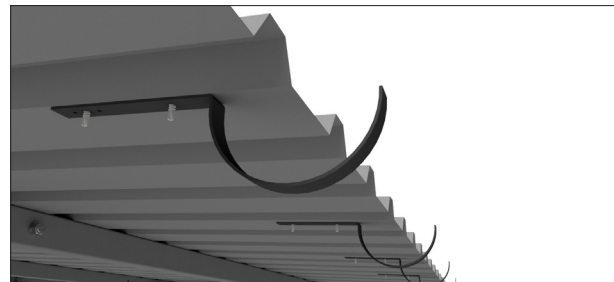

Picture 8.-4

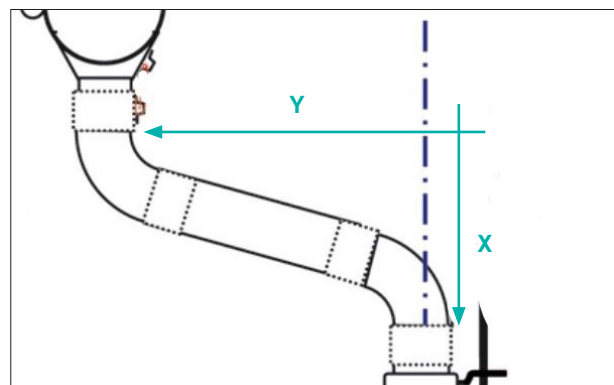

Picture 8.1-1

8.1 Downpipe

The three metre downpipe is divided into the pipe proper and the connector.

- The downpipe hopper is fixed to the roof gutter using the prepared opening.
- Fix the downpipe to the support (3) with clamps.
- The connector length is determined by the roof overhang.
- Measure the value of X and use the table below to calculate the length of the middle component.
- Cut away pieces of the drain pipe will serve as connectors.
- Fix the downpipe clamp ca. 10 cm below the lower square and above the upper square.

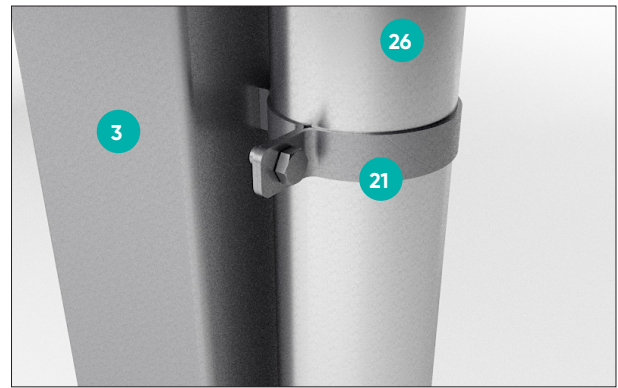

Picture 8.1-2



Picture 8.1-3

X [cm]	80	70	60
Connector length [cm]	ca. 70	ca. 60	ca. 50

9. Planning the module area for a transverse installation

For a transverse installation, use short rail pieces (GS 1/15 CS) of 100 mm. Determine the spacing using the outer dimensions of the installed modules and the spacing of the sheet metal crests. Adhere to the positioning of the clamping points as described by the manufacturer. The spacing of the rails is determined as follows:

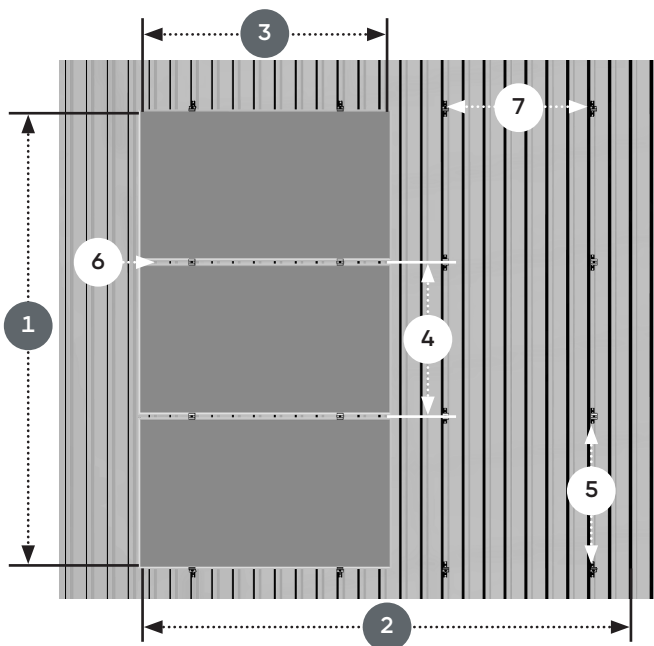

Picture 9.-1

- 1 Module field height: vertical module count x (module width + 19 mm) + 41 mm
- 2 Module field width: horizontal module count x module length (+ possible sum total of gaps)
- 3 Module length
- 4 Module width
- 5 Vertical spacing between two rail pieces: Module width – 82 mm (free space between rails, tolerance +/- 1 mm)
- 6 Free space between modules = 17-19 mm
- 7 Spacing between rail components along module column: ca. 1/ 2 x module length, depending on spacing of sheet crests (the rail pieces are fixed to the crests).



DANGER

Mortal danger due to damage to roof

Excess loads may cause grave damage to the roof!

- Before installation and fixing, make sure that the building, and in particular the roof covering, will conform to the increased static requirements due to installation of the PV system.



DANGER

Risk of death due to falling components

Components falling from the roof may cause severe injury or death!

- Before installation and assembly make sure that the used materials conform to the local static requirements!

10. Fixing the profile rails for a transverse installation

For a cross installation, install 100 mm rail components (GS 1/15 CS). EPDM insulation bands are already in place, they do not to be embedded again. The rails are fixed directly to the sheet metal crests using two thin sheet screws.



DANGER

Risk of death due to falling components

Components falling from the roof may cause severe injury or death!

- Before commencing the installation, secure the perimeter so that nobody is injured due to falling components!
- Make sure that nothing at all can fall from the roof.
- Always wear the statutory required PPE!
- Do not remain in the hazard zone!
- If the wind is too strong, cease all works.
- When installation is completed, check whether the frame and modules are properly installed.



DANGER

Mortal hazard in case of fall from the roof!

A fall from the roof may cause grave injury or death!

- Always wear the required PPE!
- Protect yourself from falling!
- If the wind is too strong, cease all works.

Installation steps::

- Determine the placement of the profile rails on the trapezoidal sheets, considering the crest pitch and the allowable installation positions of the clamps on the PV modules used.
- Using the chalk line, mark the placement of the short rails on every crest. Remember for the chalk line to be laid out exactly at 90° against the crests.
- Begin working on the first row, place the rail components exactly parallel to the crests.
- Fix the profile rail pieces to the trapezoidal sheet, always using two thin sheet screws each.
- The subsequent rail component rows are installed in exactly the same way. Remember to retain suitable vertical spacing between the rail components.

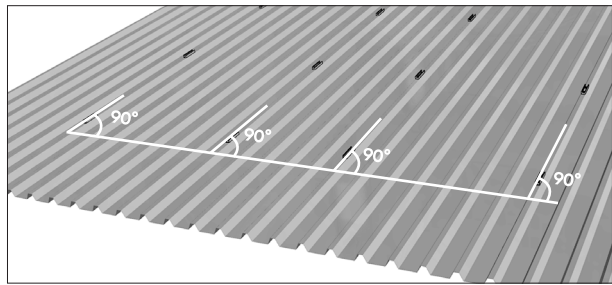

Picture 10.-1

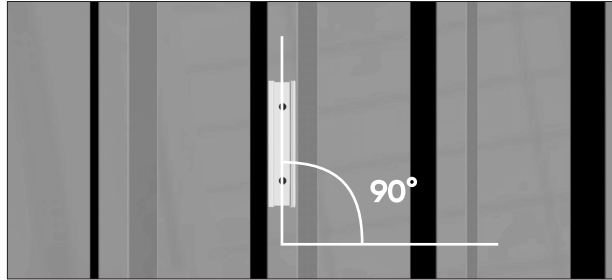

Picture 10.-2

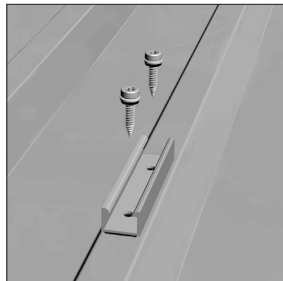

Picture 10.-3

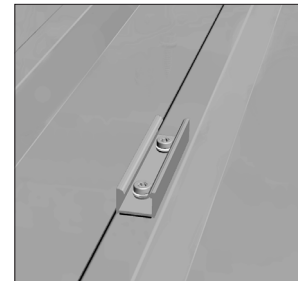

Picture 10.-4

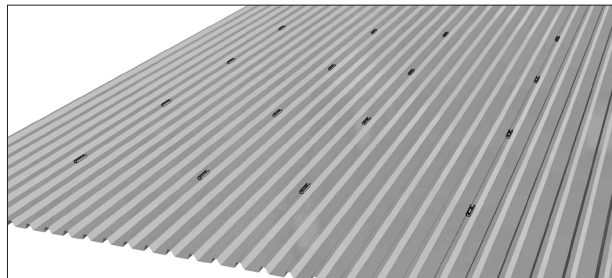

Picture 10.-5



CAUTION

Material damage due to incorrect assembly

Improperly placed thin sheet screws may be ripped out.

- Thin sheet screws must be tightened very well, yet not overtightened.

11. Transverse installation of modules

The modules are installed one after another on the profile rails. Mounting Systems GmbH recommends that modules be installed row after row, bottom to top. The modules are fixed using clamps and end clamps. The end clamps are foreseen for holding a Double module, with ordinary clamps usually placed between two modules.

11.1 Fixing the Clickstones

The installation of modules uses Clickstones. The Clickstone is a special support used to fix the profile rails. Installation requires just an Allen key (5 mm). Clickstones are slid into the profile rail channels from the top.

Installation steps:

- Slide the Clickstone into the rail channel from the top.
- Press the Clickstone down. A click will be heard as it is fixed in place.
- Tighten the Allen key with a torque of 8 Nm.

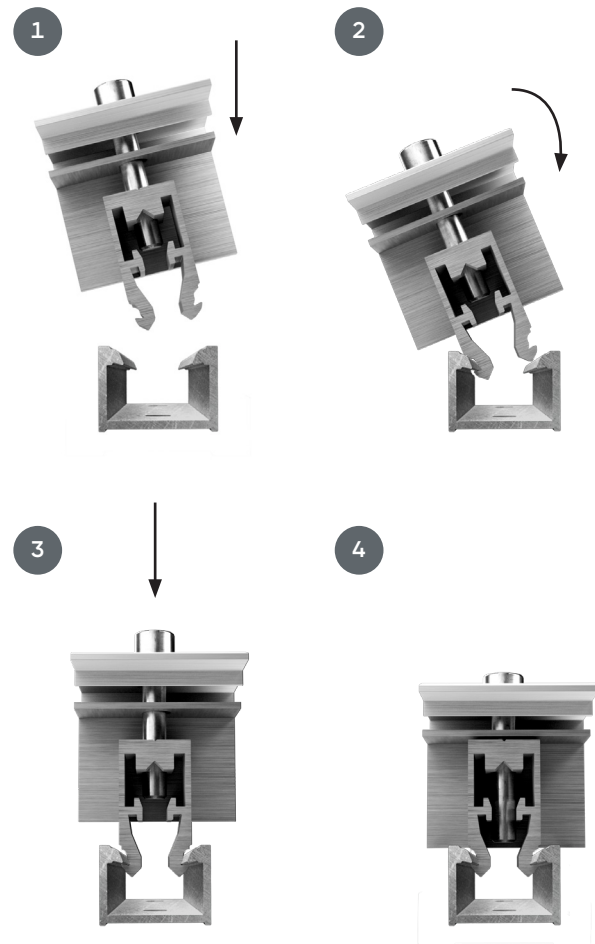

Picture 11.1-1



Note!

The Clickstone shape corresponds exactly to the channel profile. The Clickstones are constructed so that it is not easy to move them sideways so they don't slide away. In order to shift the Clickstone, press the screw down lightly and slide the component in the rail channel, pressing on it gently.

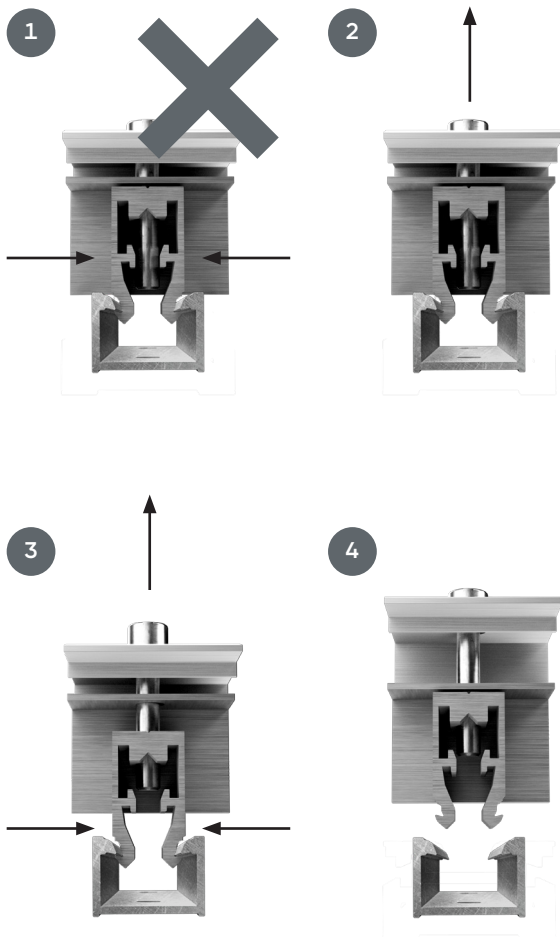

Picture 11.1-2



CAUTION

Material damage due to damage to Clickstones.

When using significantly deformed Clickstones, proper and safe installation of modules cannot be guaranteed. Modules are at a risk of falling and damage.

- Only use Clickstones, whose noses are parallel to each other, and which click audibly when locking in place.
- Replace deformed Clickstones before assembly.



CAUTION

Damage to material due to incorrect installation

Incorrectly installed Clickstones may be ripped out. The modules may fall and become damaged.

- Install all Clickstone connections as foreseen by the manual.



Note!

The noses on the internal sides of the Clickstones are constructed so that it is impossible for them to become dislocated when the screw is tightened. Accordingly, the screw may be loosened slightly so that it protrudes above the nose level; only then remove the Clickstone from the base rail by compressing it slightly and raising it.

11.2 Fixing the modules from the outside

Edge modules in a PV arrangement (and for a transverse installation – the top and lowest module row) are fixed from the outside using two edge clamps at the top and two at the bottom.

Installation steps:

- Slide the Clickstone for the end clamp after centering it in the rail channel.
- Put the module on top and level it.
- Slide the module end clamp all the way to the frame.
- Tighten the screw (torque: 8 Nm), the module is clamped.

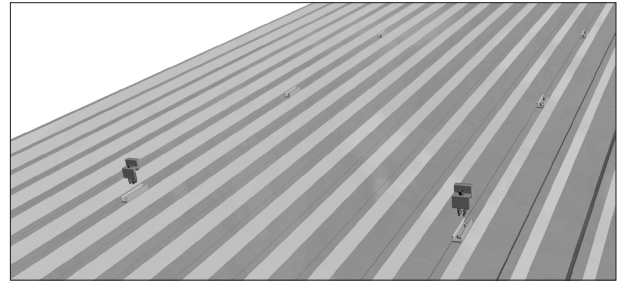

Picture 11.2-1

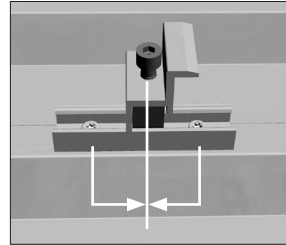

Picture 11.2-2

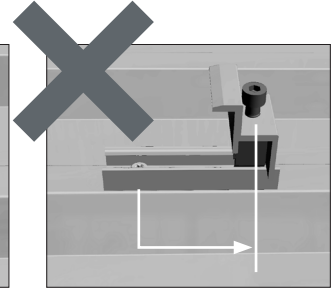

Picture 11.2-3

Proper placement of the end clamp: Centrally, between the thin sheet metal screws!

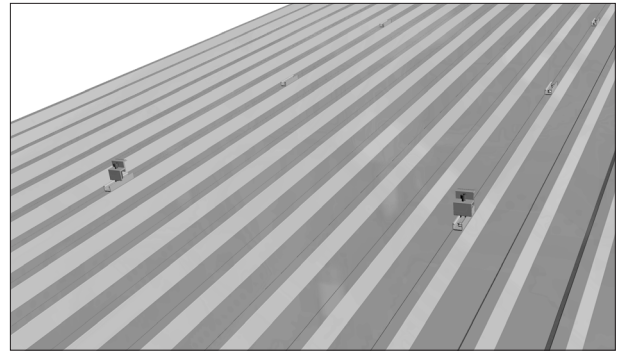

Picture 11.2-4



CAUTION

Material damage due to incorrect installation

Modules install the wrong way may fall and become damaged.

- Make sure the Clickstones are fixed properly.
- Slide the module all the way to the end clamp.
- When tightening screws, adhere to the indicated torque values.
- After installation make sure that the module really is fixed well.

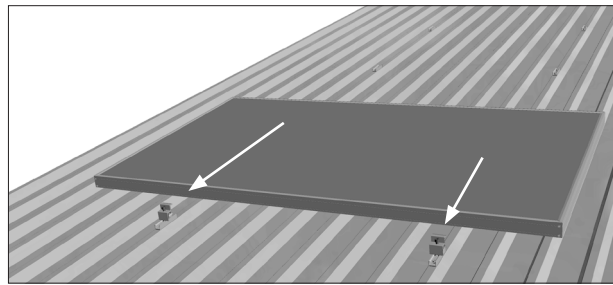

Picture 11.2-5

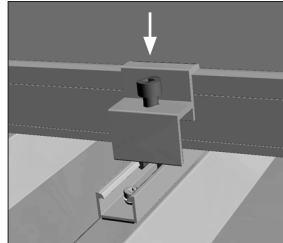

Picture 11.2-6

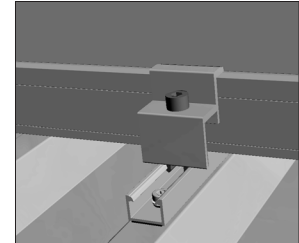

Picture 11.2-7



CAUTION

Material damage due to incorrect installation

Overloaded thin sheet screws may be ripped out.

- Note the correct placement of the module end clamps. The Clickstone must be found between both thin sheet screws in the rail component.

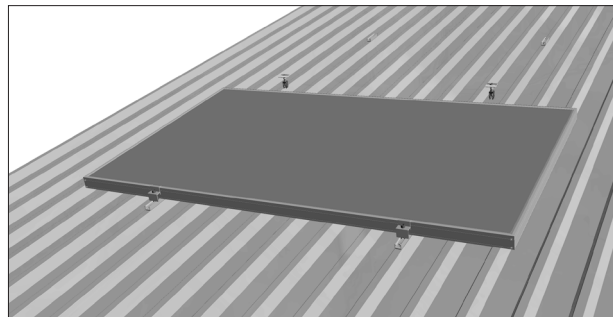

Picture 11.2-8

11.3 Fixing the modules from the inside

Always fix two module clamps between modules.

Installation steps:

- Embed the Clickstone in the profile rail channel.
- Slide the module clamp all the way to the frame of the module already installed.
- Slide the second module to the module clamp; lay out properly.
- Tighten the screw (torque: 8 Nm), so the module is properly fixed.

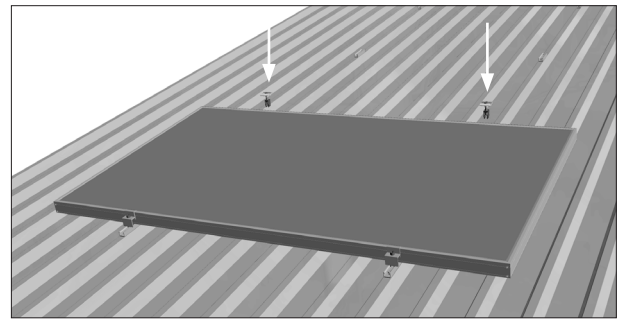

Picture 11.3-1

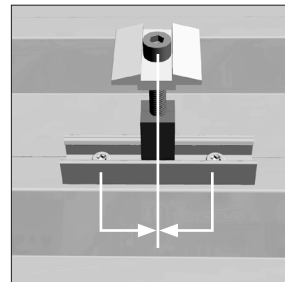

Picture 11.3-2

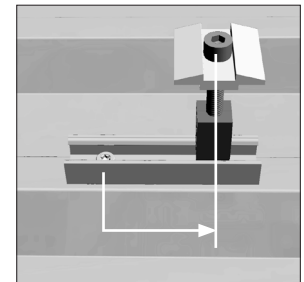

Picture 11.3-3



CAUTION

Material damage due to incorrect installation

Modules install the wrong way may fall and become damaged.

- Make sure the Clickstones are fixed properly.
- Slide the module all the way to the end clamp.
- When tightening screws, adhere to the indicated torque values.
- After installation make sure that the module really is fixed well.

Proper placement of the end clamp: Centrally, between the thin sheet metal screws!

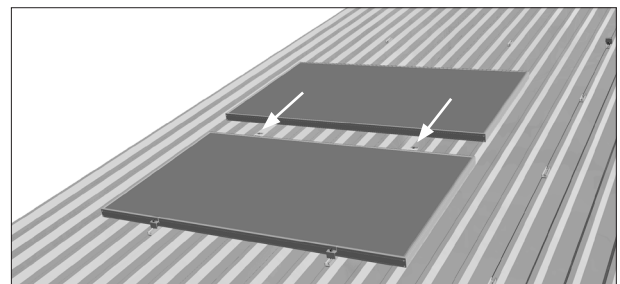

Picture 11.3-4

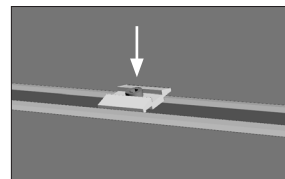

Picture 11.3-5

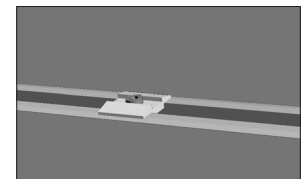

Picture 11.3-6



CAUTION

Material damage due to incorrect installation

Overloaded thin sheet screws may be ripped out.

- Note the correct placement of the module end clamps. The Clickstone must be found between both thin sheet screws in the rail component.

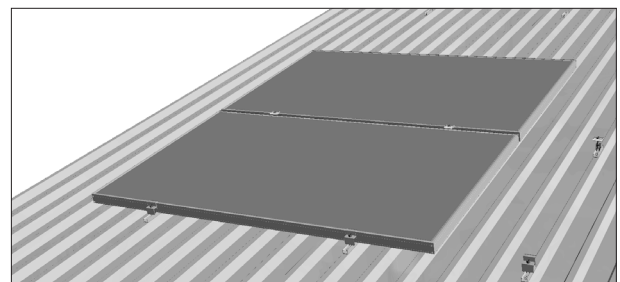

Picture 11.3-7

11.4 Fixing further rows

Installation steps:

- For the further columns, the modules must be slid from the side to the modules of the first outer row. For optical reasons, if necessary, one may retain a specific spacing from the lower module.



Note!

Use e. g. the module clamp as a distance indicator. In this way, one can achieve the same vertical and horizontal distances between modules.

- Fix the modules from the first column using clamps and end clamps (see 10.2 and 10.3).

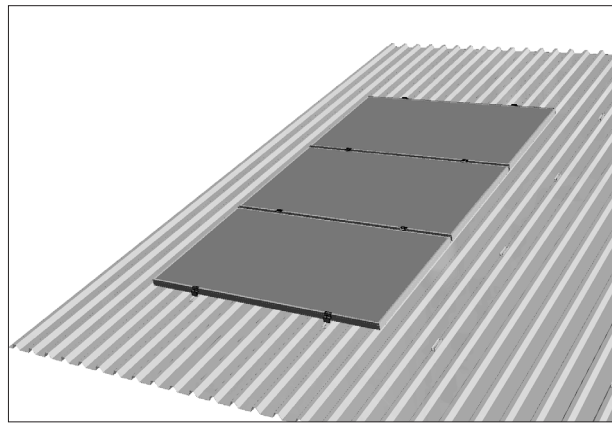

Picture 11.4-1

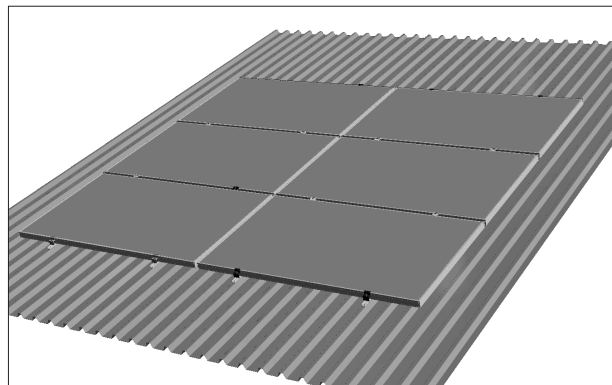

Picture 11.4-2

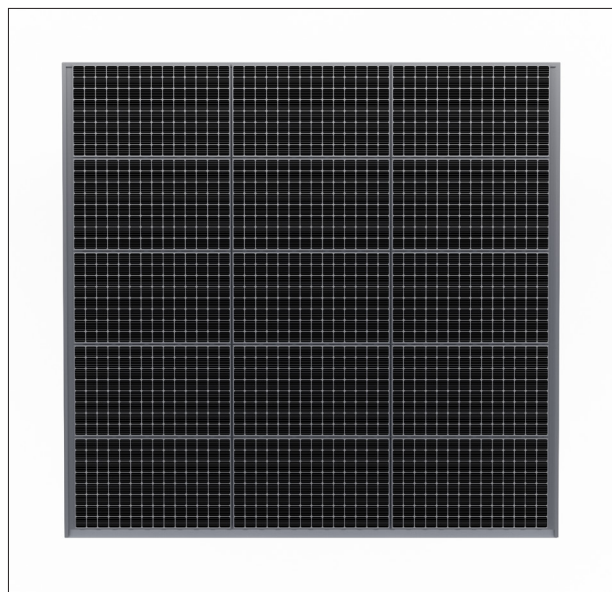

Picture 11.4-3 Module field E-Port Home Double



**mounting
systems**



Mounting Systems GmbH
Mittenwalder Straße 9a
D-15834 Rangsdorf

Tel: +49 33708/529-100
Fax: +49 33708/529-199

info@mounting-systems.com
www.mounting-systems.com

Mounting Systems GmbH
Rolshover Straße 524
D-51105 Köln

Tel. +49 221-29277-600
Fax: +49 221-29277-629

Technische Änderungen vorbehalten 2021 © Mounting Systems GmbH