



# Quick Installation Guide

## X3-Hybrid 5kW-10kW

### II Mounting Steps

1 - Mark position of five holes.

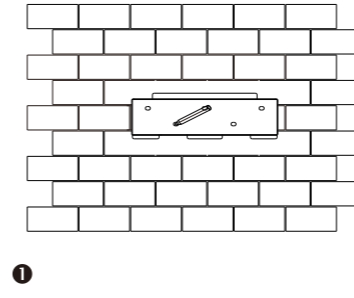

2 - Drill holes with  $\phi 10$  drill.  
- Depth: at least 60mm.

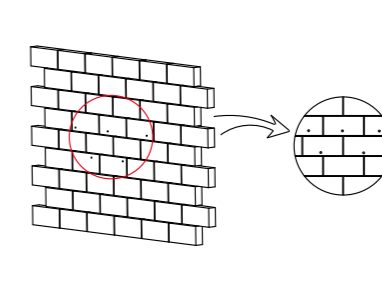

3 - Tighten the expansion tubes.

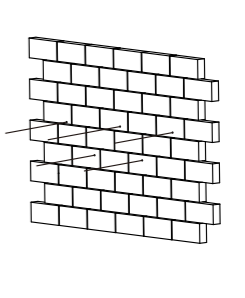

4 - Screw the expansion screws.  
 $\phi 10$  drilling machine Power:  $2.5 \pm 0.1\text{Nm}$

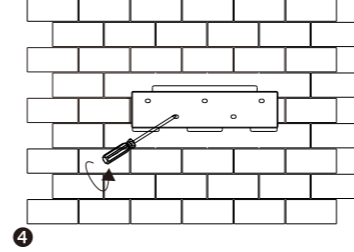

5 - Match the inverter with the bracket.  
- Buckle the back card of the inverter back to the back of the wall.

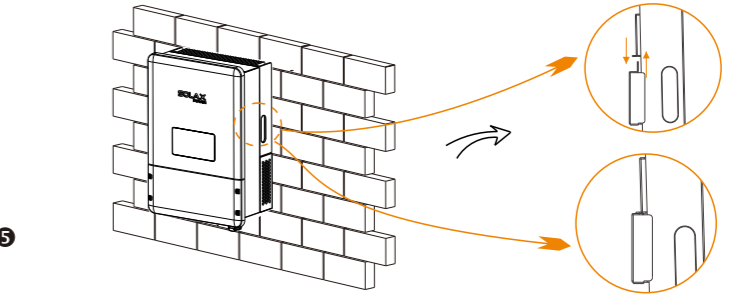

### I Packing List

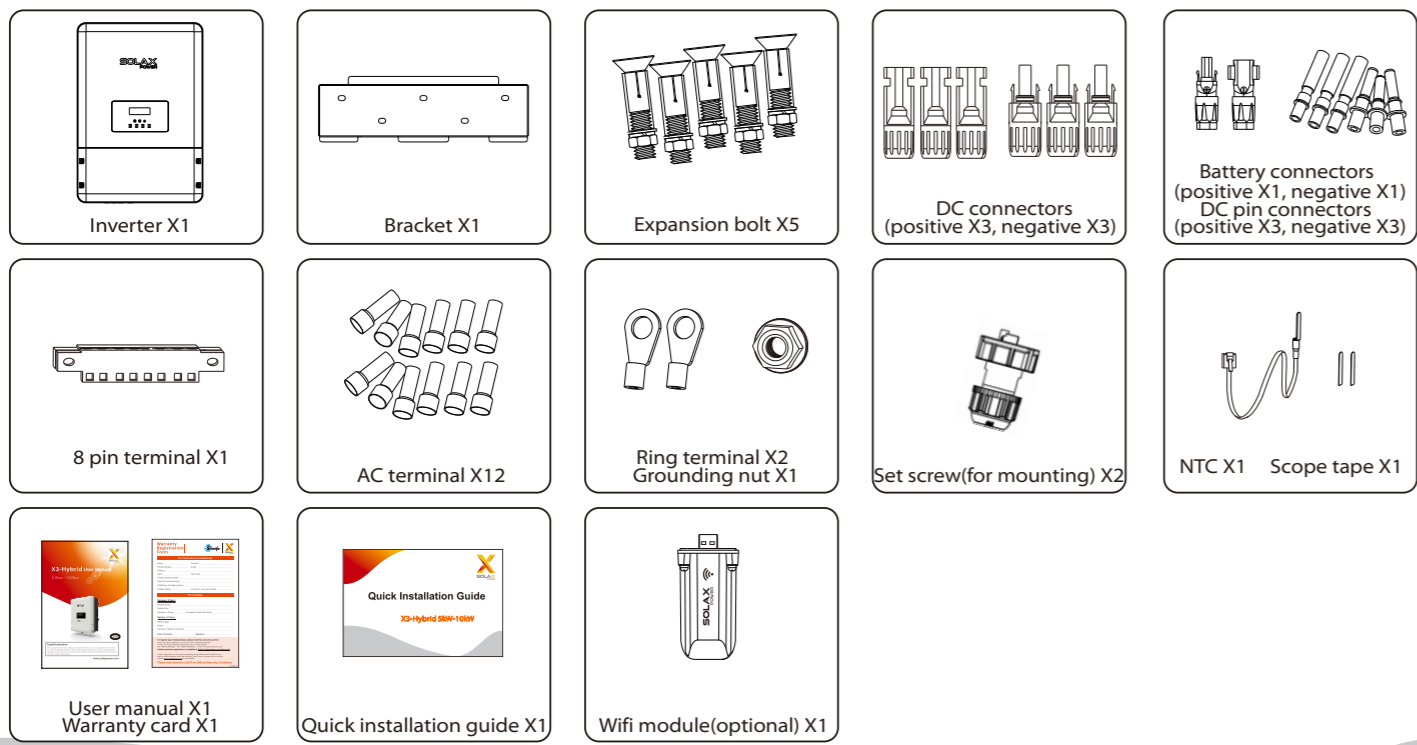

### III PV and AC Connection

PV connection steps (PV cable size: 12AWG):

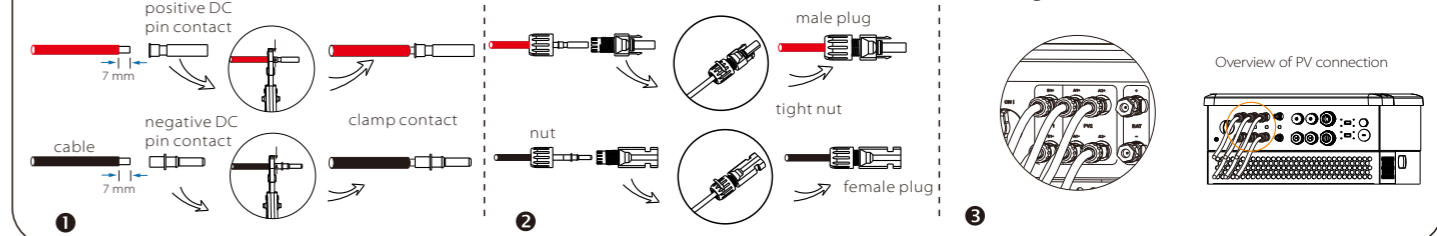

AC connection steps (AC cable size: refer to table 1):  
( $\phi 4$  hexagon wrench, torque:  $3 \pm 0.1\text{Nm}$ )

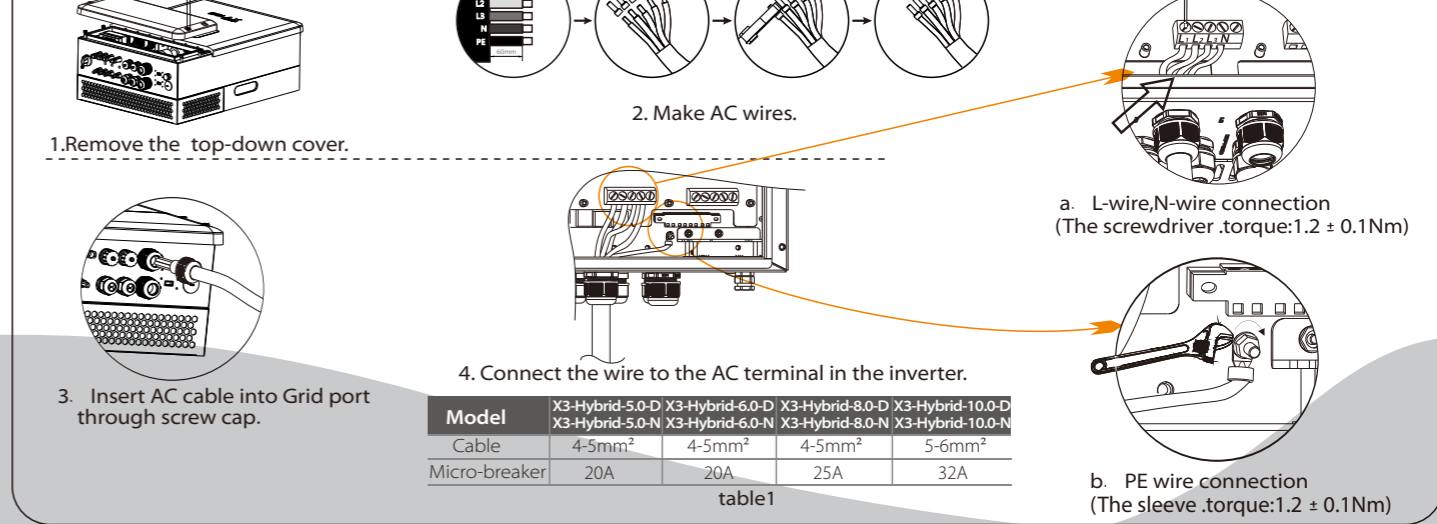

Model	X3-Hybrid-5.0-D	X3-Hybrid-6.0-D	X3-Hybrid-8.0-D	X3-Hybrid-10.0-D
Cable	4-5mm <sup>2</sup>	4-5mm <sup>2</sup>	4-5mm <sup>2</sup>	5-6mm <sup>2</sup>
Micro-breaker	20A	20A	25A	32A

table 1

### IV EPS Connection (for E Version)

EPS wiring diagram

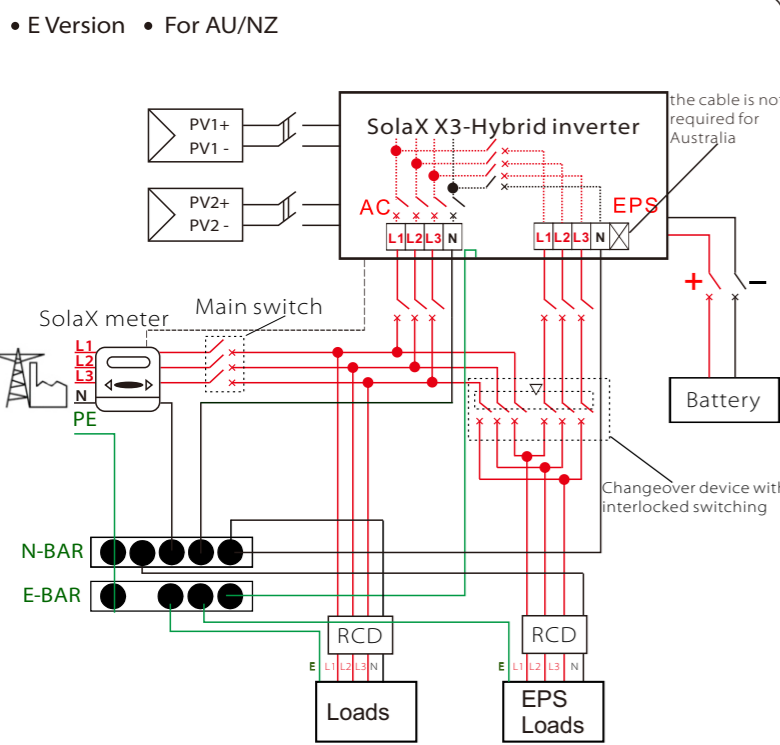

EPS connection steps:

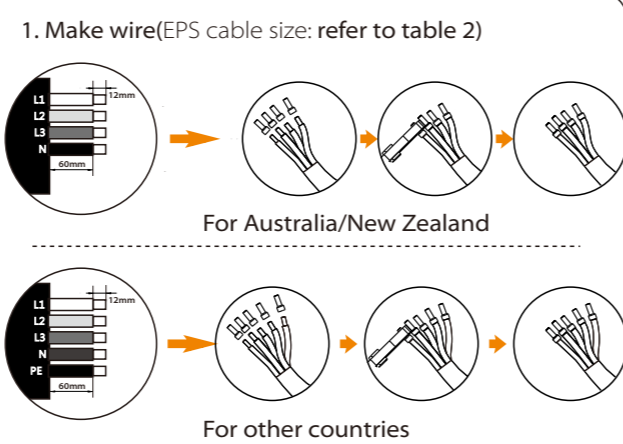

Model	X3-Hybrid-5.0-D	X3-Hybrid-6.0-D	X3-Hybrid-8.0-D	X3-Hybrid-10.0-D
EPS Cable	$\geq 5\text{mm}^2$	$\geq 5\text{mm}^2$	$\geq 5\text{mm}^2$	$\geq 5\text{mm}^2$
EPS breaker	25A	25A	32A	32A

2. Insert EPS cable into EPS port through screw cap.  
(One-word screwdriver. Torque:  $1.2 \pm 0.1\text{Nm}$ )

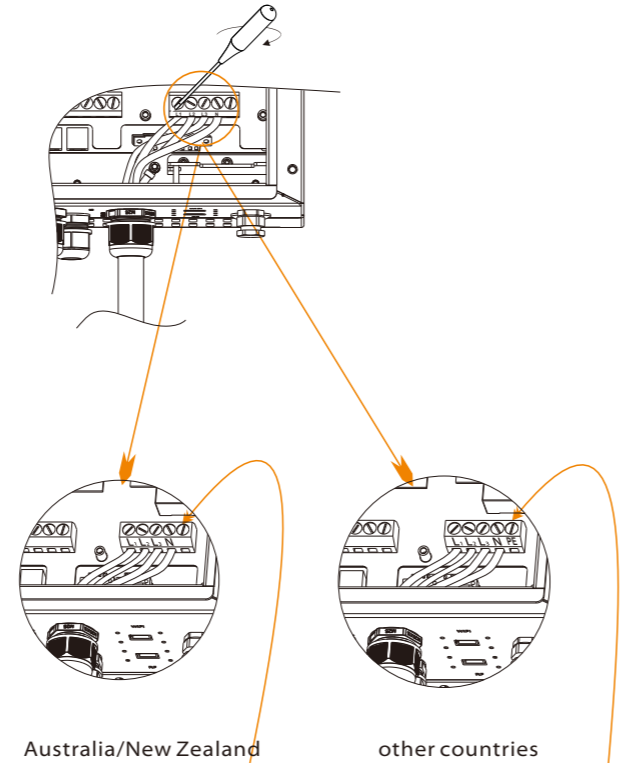

Note: The right most port should not be connected!  
Note: Connect PE wire into PE port at right!

• E Version • For Other Countries

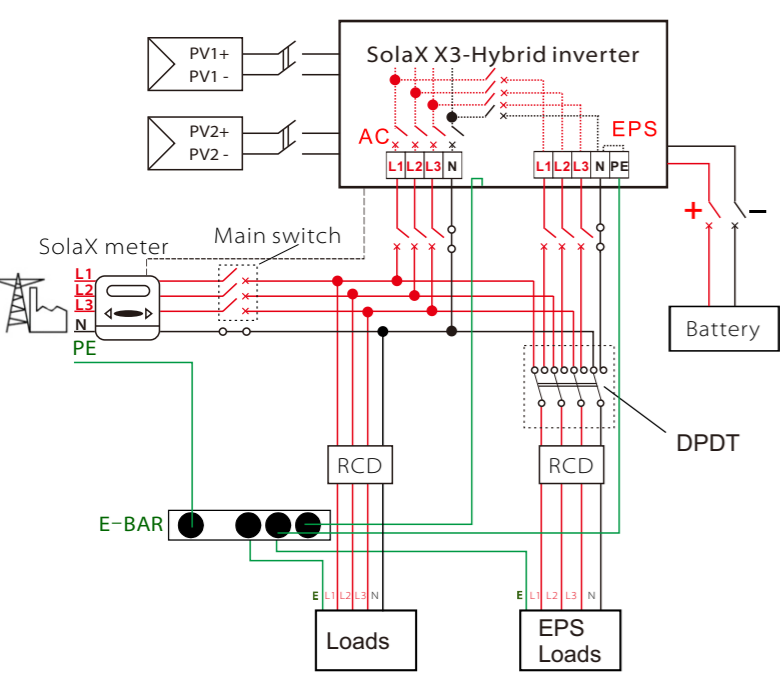

This function can be achieved manually or automatically according to user's preference.  
For manual solution, please install an external switch.  
For automatic solution, please contact our sales.

### V Lithium Battery Connection (optional)

Battery connection diagram

Note: For lead-acid battery connection, please refer to Important Instruction for lead acid battery.

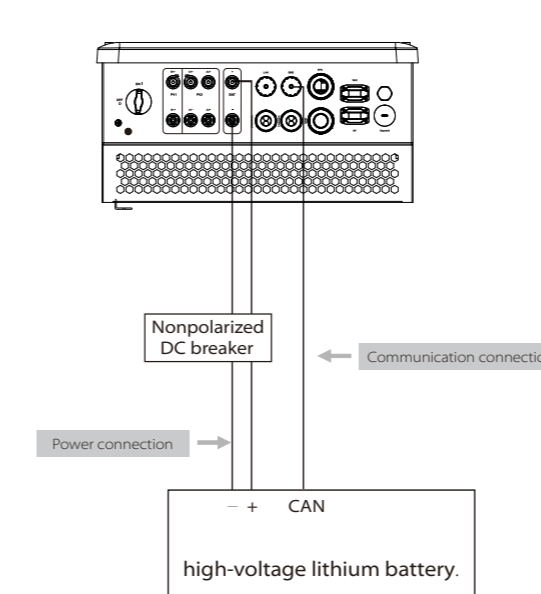

Battery breaker

Before connecting to battery, please install a nonpolarized DC breaker to make sure inverter can be securely disconnected during maintenance.

Model	X3-Hybrid-5.0-D	X3-Hybrid-6.0-D	X3-Hybrid-8.0-D	X3-Hybrid-10.0-D
Voltage	Nominal voltage of DC breaker should be larger than maximum voltage of battery.			
Current[A]	32A			

BMS PIN Definition

Communication interface between inverter and battery is CAN with a RJ45 connector.

PIN	1	2	3	4	5	6	7	8
Definition	NTC	GND	GND	BMS_CANH	BMS_CANL	GND	BMS_485A	BMS_485B

Note: The battery communication can only work when the battery BMS is compatible with the inverter.

A: Power Connection Steps:

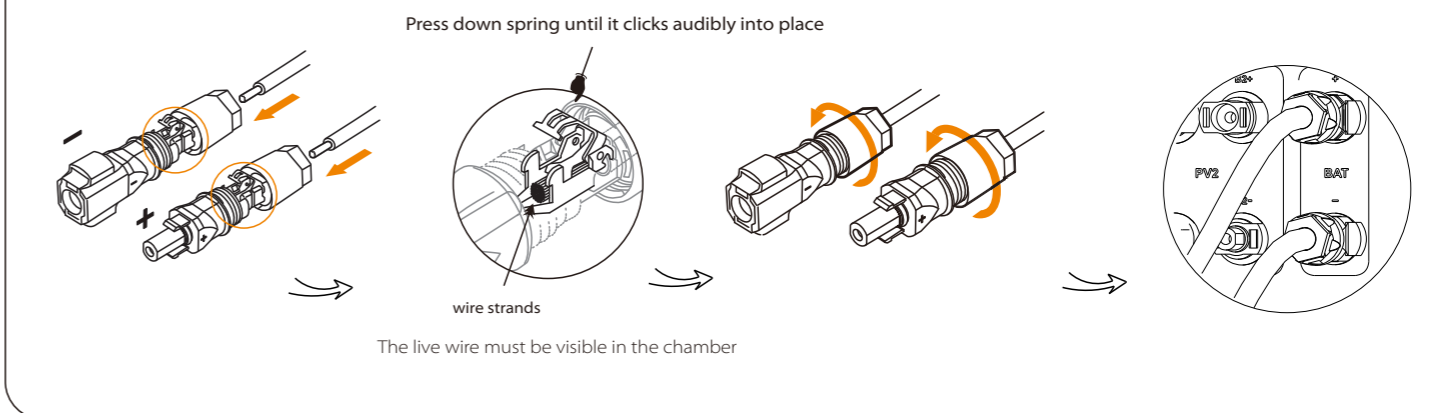

B: Communication Connection Steps:

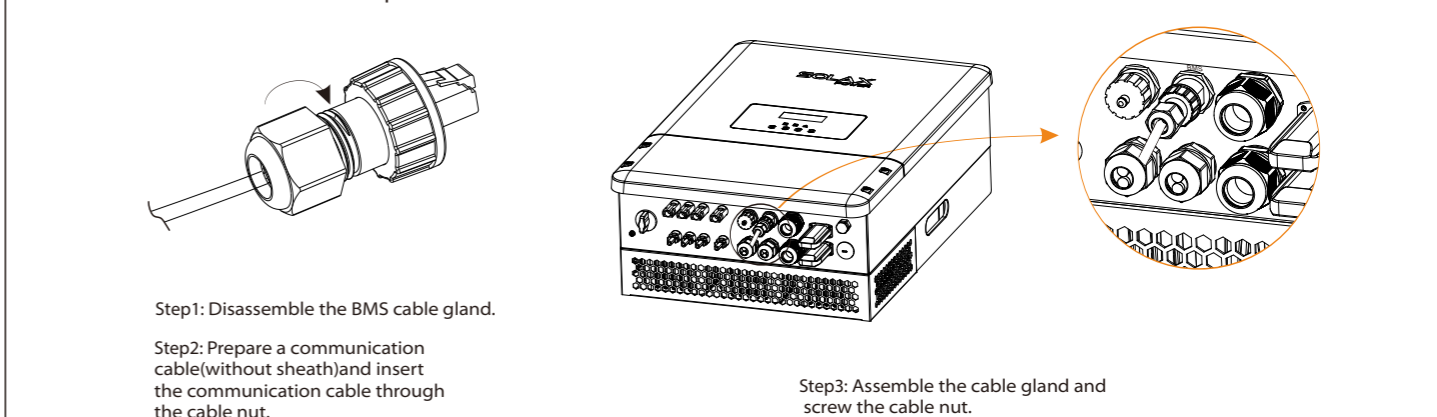

## Meter connection diagram

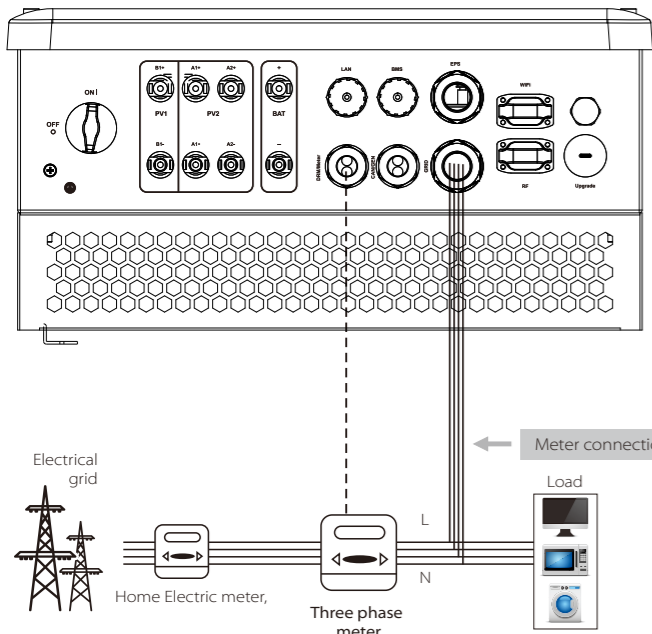

Connect the RS485 line from meter with a RJ45 connector and finish the configuration, then plug this RJ45 connector to the "Meter" port of the inverter.  
Note: Please make sure meter A and meter B is connected to port RS485A and RS485B on the meter.

## Meter connection step

1) Insert L/N wires and the 485A/B cable into the meter. (detail please see meter manual)

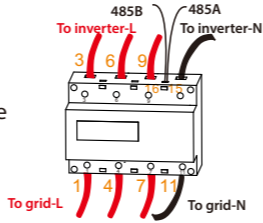

2) Insert the other side of the cable into the meter port on the inverter.

a. Unscrew the cable nut of Meter connector and insert two communication wires through it.

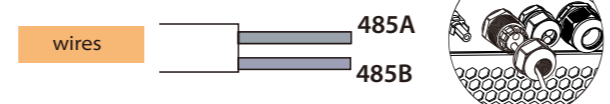

b. Strip the insulation from the communication cable, and then insert it into a 8 pin green terminal. (torque: 0.4 ± 0.1 Nm)

c. Insert the terminal into corresponding Meter terminal block inside of the inverter. (torque: 0.4 ± 0.1 Nm)

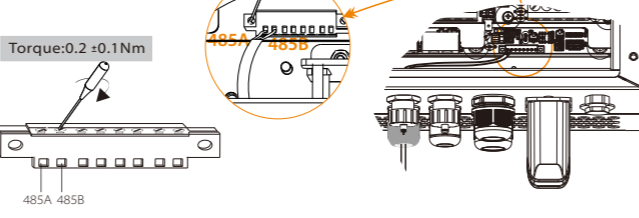

## Firmware Upgrading

## Preparation

Please ensure the inverter is steadily powered on. Inverter must connect PV panels and keep the battery on through whole procedure of upgrading. Please prepare a PC and make sure the size of U-disk is under 32G, and the format is fat 16 or fat 32.

**Warning!** Make sure the PV input power is more than 180V (operate the upgrade on a sunny day), otherwise it may result in serious failing during upgrading.

1) Please contact our service support to get the update files, and extract it into your U-disk as following (Don't modify the file name):

"update\ARM\618.00098.00\_Hybrid\_X3G3\_Manager\_VX.XX.XX.XX.usb";  
"update\DSP\618.00096.00\_Hybrid\_G3X3\_Master\_VX.XX.XX.XX.hex";

2) Press the "Enter" key for 5 seconds to enter Off Mode. Then unscrew the waterproof lid and insert U-disk into the "upgrade" port at the bottom of the inverter.

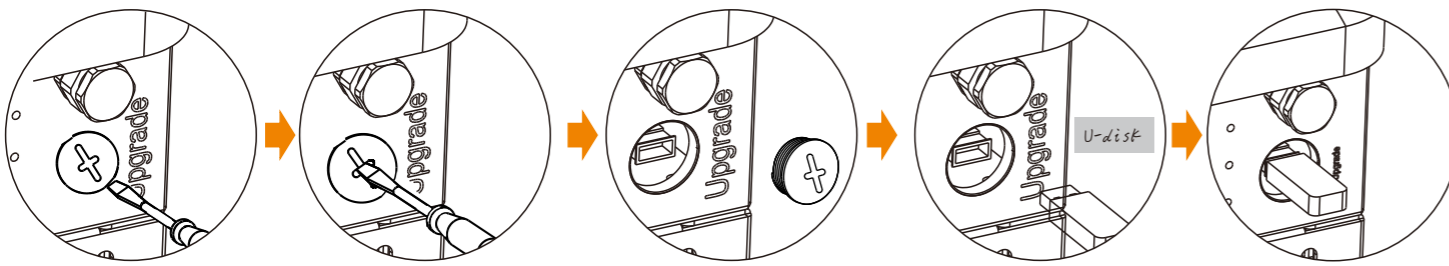

3) The LCD will be shown as the picture. Then press up and down to select the one that you want to upgrade and press "OK" to confirm to upgrade.

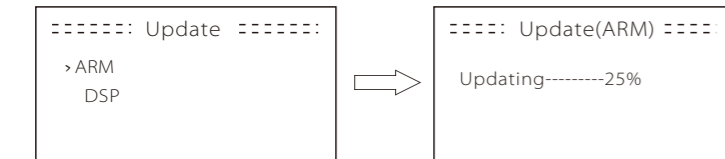

4) After the upgrade is finished, the LCD will display "succeed" (only for DSP upgrades), please remember to pull off the U-disk, screw the waterproof lid and press the "Esc" to return to the Main interface. Then press the "Enter" key to exit Off Mode.

## Start Guide

## 1. Set language

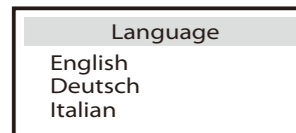

## 2. Set date time

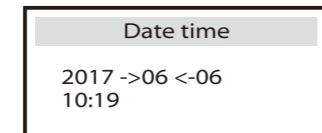

## 3. Set the safety standard



## 4. Set export control



This function allows the inverter able to control energy exported to the grid. There are user value and factory value. The factory value is default which can not be changed by user. The user value set by installer must be less than the factory value. The meaning of the set number is the max. output power allowed. If the user do not want feed any power into grid, then please set it to 0.

## 5. Set work mode

There are 4 work modes for choice.  
Self use/ Back up mode/ Feed in Priority/ Force Time Use  
All these work modes is available for on-grid condition only:

Parameter	Comment
Self Use (default)	The PV generated power will be used to supply the local loads first, then to charge the battery. The redundant power will export to the public grid. When there is no PV supplied, battery will discharge for local loads first, and grid will supply power when the battery capacity is not enough. The priority of inverter output power is: supplying the load → charging the battery → feeding to the grid.
Back Up Mode	Battery will stop discharging to keep higher capacity when the grid is on. When the power generated by PV is not enough, the battery will discharge to supply the local loads too. And if still not enough, the grid will power the local loads together. This work mode applies to the area where suffering from blackout regularly.
Feed in Priority	The priority of inverter output power is: feeding to the grid → supplying the load → charging the battery. This work mode applies to the area with high feed-in tariff.
Force Time Use	In this work mode the charging and discharging time can be set flexibly, and it also allows to choose whether charge from the grid or not. Other time it follows the priority of Self Use mode.

## 6. Set EPS system (For E Version only)

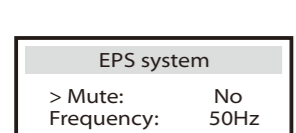

X3-Hybrid inverter with E Version can work on the EPS mode. EPS parameters can be set as below.  
"Mute" means you can set the warning of system which has entered EPS mode.  
- "No" means there will be a buzzing and it is the default value.  
- "Yes" means you choose to shut down the warning function.

Besides, if the buzzing is sharp, it means EPS output is over loads.  
Frequency "here can be set 50Hz or 60Hz please based on correlative loads.

## Earth Connection Steps (mandatory):

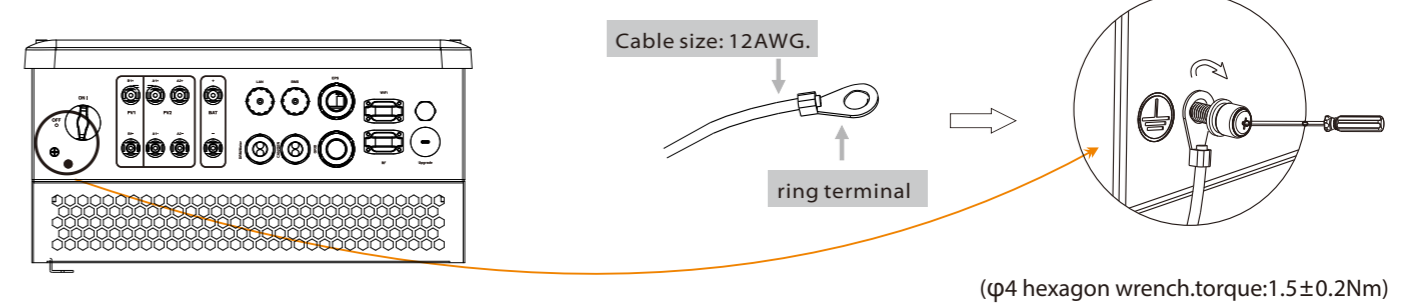

## Start inverter

Applies to most countries

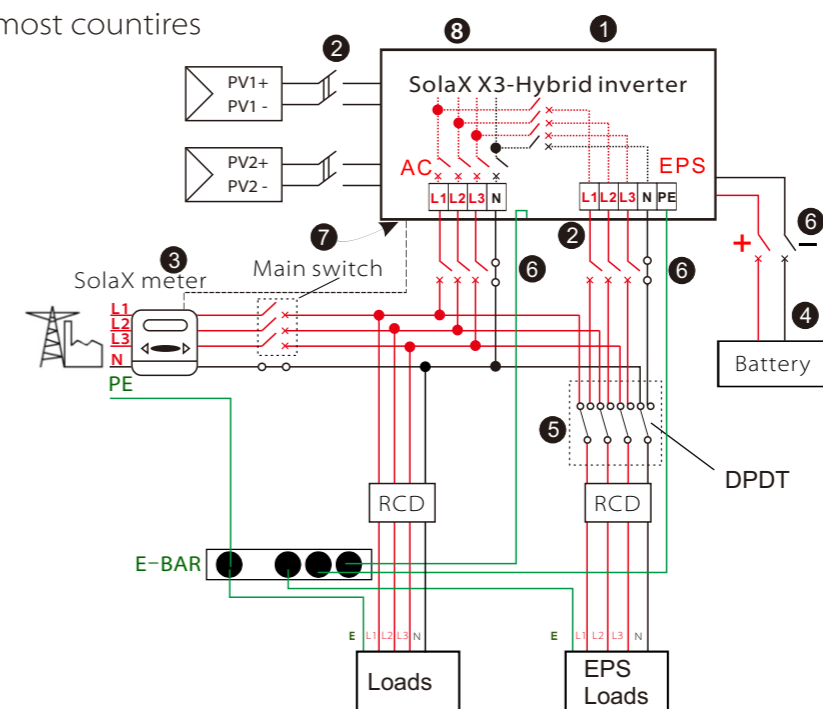

- 1 Ensure the inverter fixed well on the wall.
- 2 Make sure all the DC wirings and AC wirings are completed.
- 3 Make sure the meter is connected well.
- 4 Make sure the battery is connected well.
- 5 Make sure the external EPS contactor is connected well. (if needed)
- 6 Turn on the AC switch, EPS switch and battery switch.
- 7 Turn on the DC switch at the bottom of the inverter to "ON" position.
- 8 Long-press the "Enter" key for five seconds to exit Off Mode. (The mode is Off Mode when you use it for the first time; Factory default: Off Mode)

Inverter will start up automatically when the PV panels generate enough energy or the battery is discharging.

Check the status of indicators and LCD screen. The left indicator should be blue and the indicator screen should display the main interface.

## Monitoring Operation

Solax provides two ways for users to choose: WiFi (optional) and Ethernet (LAN)

## WiFi (optional)

Inverter provides a WiFi port which can collect data from inverter and transmit it to monitoring-website via a Pocket WiFi. (Purchase the product from supplier if needed)

## Diagram

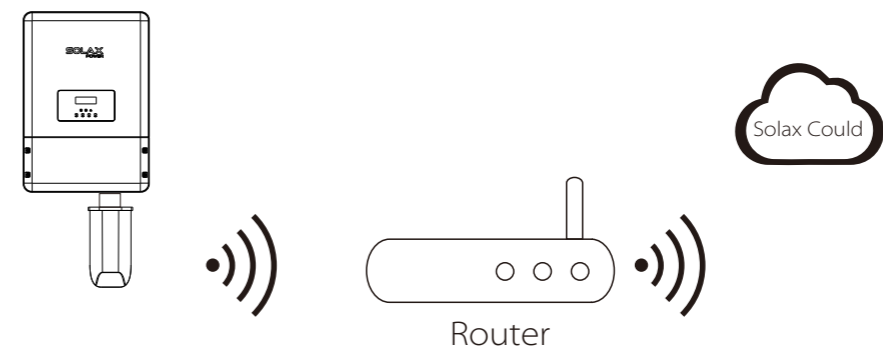

## WiFi Connection Steps:

Step 1. Plug Pocket WiFi into "WiFi" port at the bottom of the inverter.

Step 2. Build the connection between the inverter and router.

Step 3. Create an user account online.

(Please check the Pocket WiFi user manual for more details.)

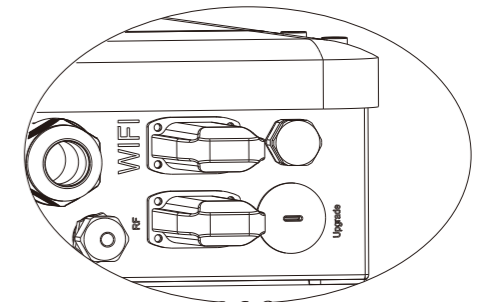

## Ethernet (LAN)

LAN communication is the standard communication interface. It can transmit the data between the router and inverter via the local network.

## Application Occasion

This function is applicable for the below situation:  
When the wifi signal is too weak to transmit data, user can use LAN port for the monitoring with a data cable.  
Note: The wifi module still needs to be connected when using LAN connection.

## LAN PIN Definition

Communication interface between inverter and router is RS485 with a RJ45 connector.

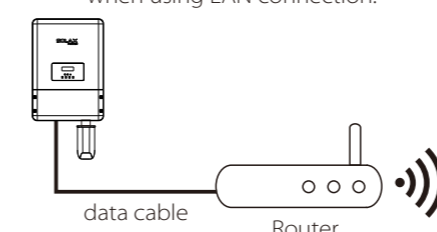

Pin	1	2	3	4	5	6	7	8
TX+								
TX-								
RX+								
X								
X								
RX-								
X								
X								

## LAN Connection Steps:

Please refer to BMS connection steps (for user manual page 32) for LAN connection. Please kindly noted the PIN definition and port position will be slightly different. (The inverter needs to be set to DHCP)

